

SF Outdoor Fountain

Solar Operated Bottle Filling Station, Dual Fountains and Dog Bowl

FOUNTAIN SPECIFICATIONS

FOUNTAIN MATERIALS & FINISHES

- Sheet Metal Parts:
 - Mounting Bracket: 10ga stainless steel
 - Frame/Base: 1/4" black steel
 - Outer Wrap & Access Panels: 14ga #4 stainless steel, powder coated "Filtrine Green"
- Other Parts: Satin #4 stainless steel bowl and bubblers, powder coated bronze

FOUNTAIN CONTROLS

- [2] Foot Activated Sensors: Control bottle filler [and] dog bowl
- [4] "Hands Free" Sensors: Control left and right bubblers, bottle filler and dog bowl water dispenser

FOUNTAIN FEATURES

- "Hands Free" sensors powered by 15W solar panel
- 12V, 7Ah battery stores generated electricity
- Foot pedals and "Soft Touch" buttons serve as backup to sensors in case of electrical failure
- Tamper resistant screws prevent vandalism to fountain components
- UV sterilizer ensures water is clean for every user

NOTE: THIS IS A PROTOTYPE DESIGN

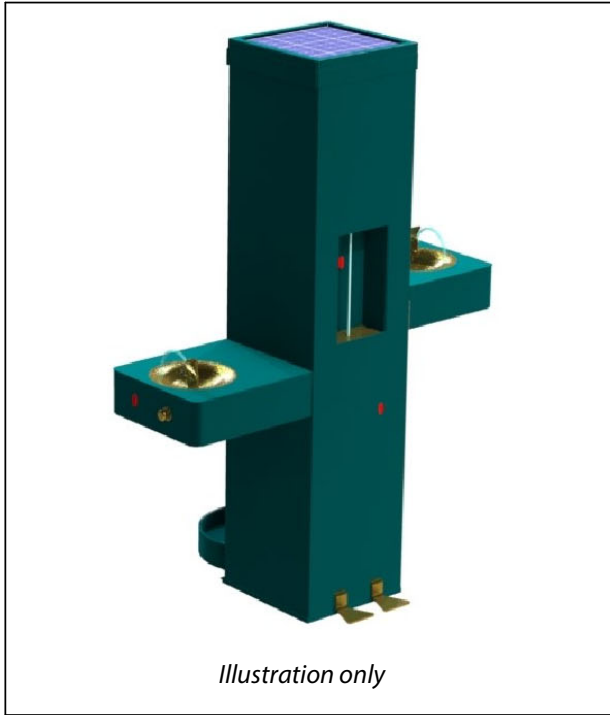

Illustration only

