



B103-107-14-MOD-HL-HF

Touchless Recessed Water Bottle Filling Station with High/Low Non-Recessed Drinking Fountains, All with "Hands Free" Sensors



Water bottle filling station, fountain bowls, support arms and access panel shown in #4 satin standard stainless steel finish with "Hands Free" sensors, label and bubblers in mirror finish

Dimensions in drawing subject to options selected.

Features

- [2] 14" diameter, 16 ga. fountain bowls
- Long-lasting, durable stainless steel water dispenser, promotes refilling of water bottles
- "Hands Free" sensors help prevent germ transmission and water waste
- One-piece cover plate with no seams or exposed edges
- No plastic parts
- Manufactured with lead-free materials
- Integral drain in bowl for ease of cleaning
- 1/4" steel support arm and wall bracket capable of supporting 500 lbs.
- Matching cover plate finishes including unlimited powder coat colors
- Options include tamper resistant screws, bottle counters, finishes, bubbler valves and much more...

Recommended Add-ons

Chiller

Equip your fountain with a Filtrine point-of-use or remote chiller to cool your drinking water. We can help you select the most economical chiller model to fit your demand.

Purifier

Ensure that your drinking water is of the highest quality by adding a Filtrine Taste Master® purifier cabinet underneath the fountain or a remote purification system serving all fountains in the building.

Top View

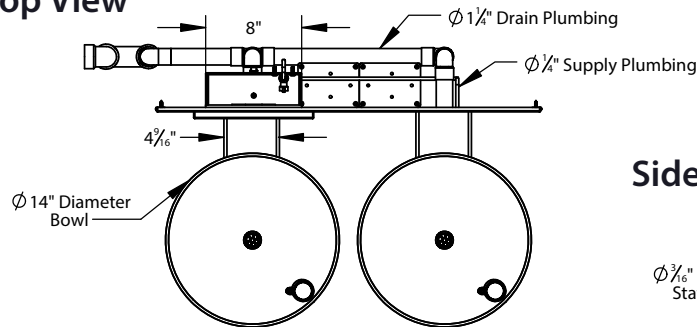

Select Low Fountain Bowl Location
 Left [S] Right

Side View

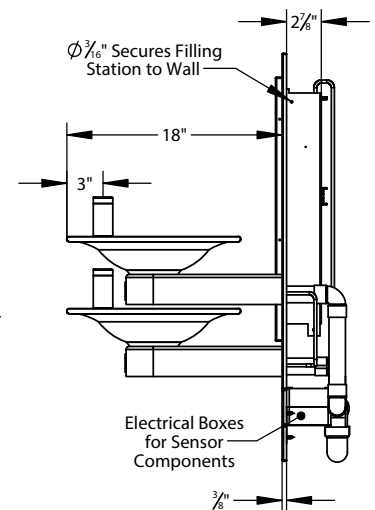

Front View

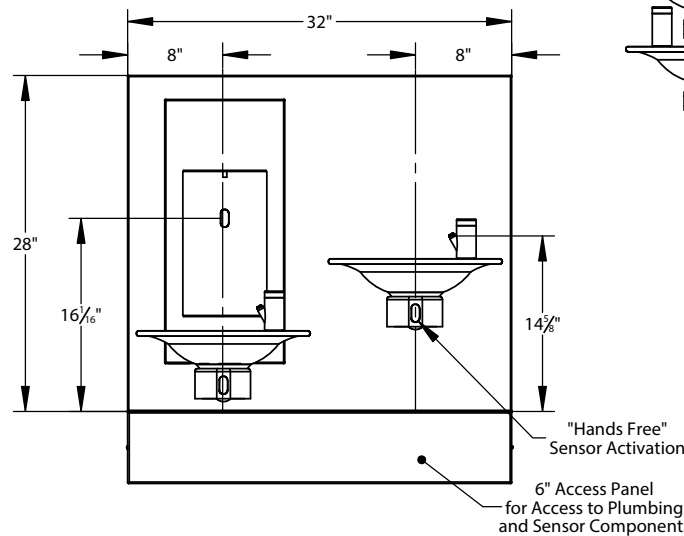

For options, finishes and more see page 2



Optional Bottle Counter

Digital display of approximate number of bottles saved through fountain usage

Note: Only available with sensor activation



Vandal Proof Options

Optional Tamper Resistant Screws

Tamper Resistant Set Screw
Secures Bubbler to Fountain

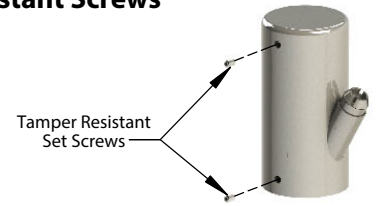

Optional Fountain Security Panel

16 ga. Plate Secured with Tamper-Resistant Screws for Added Security

4x-Tamper Resistant Screws

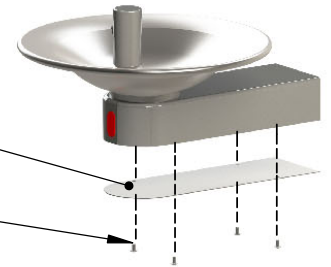

Labels (Choose one or both [S])

Permanent labels adhere to the bottle filling station cover plate. These labels convey to the user that the bubbler and filling station are operated by sensors.

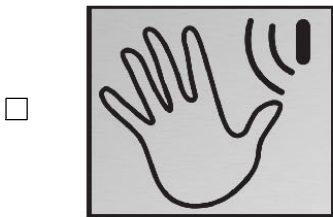

Optional F-502 Bubbler

Alternative "Hands Free" Bubbler to the Default F-503 Bubbler

Optional F-502 Tamper-Resistant Screw

Tamper-Resistant Set Screw
Secures Bubbler to Fountain



Bottle Filling Station & Fountain Finish (Check One)

Satin Stainless [S] Mirrored Stainless Powder Coat _____ Satin Bronze Mirrored Bronze Statuary Bronze Oil-Rubbed Bronze

Optional Cover Plate Finish (Check One)

Satin Stainless [S] Mirrored Stainless Powder Coat _____ Satin Bronze Mirrored Bronze Statuary Bronze Oil-Rubbed Bronze

Stainless



Satin Stainless Steel [S]



Black Powder Coat



Mirrored Stainless Steel



White Powder Coat

Bronze



Satin Bronze



Statuary Bronze

Mounting Plate Details (Front)

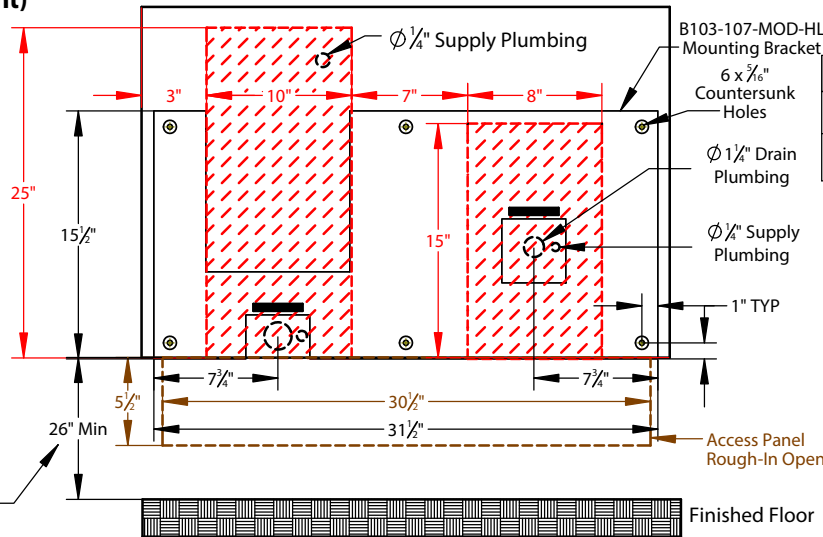

Approximate Rough-In Dimensions (hatched, left)

Model	Height	Width	Depth
High 107 Rough Opening	15"	8"	6"
B103-Low 107 Rough Opening	25"	10"	4"

Approximate Access Panel Rough-In Dimensions (outlined, left)

Model	Height	Width
Standard Panel	5 1/2"*	30 1/2"

*If height specified, rough-in height will be 1/2" less than specified height

All views shown are for typical installation of B103-107-14-MOD-HL-HF. Views, dimensions and diagrams may change for specific installation requirements.

26" Minimum From Bottom of Mounting Plate to Finish Floor Equals 34 1/4" to Bubbler Spout and 47" to Bottle Filler Spout

Exploded On-Wall Installation View B103-107-14-MOD-HL-HF

Typical Assembly Instructions (Always Install Per Local Code)

Cut rough opening for fountain, bottle filler and access panel as shown above and install blocking or fixture carrier as required to support the assembly.

1. Run drain piping to the slip coupling unions (shown below) and install drain trap per local code
2. Run supply water lines to bottom of rough opening.
3. Fasten mounting plate over rough opening with 5/16" countersunk lag bolts with bottom of plate 26" above the floor to meet ADA fountain height requirements.
4. Install cover plate over the mounting plate.
5. Measure, mark and install the included access panel "L" brackets with #8-32 screws and align access panel to cover plate with alignment pins.
6. Place B103 bottle filling station in cover plate opening and mount in place using holes located on the side of the B103 frame.
7. Slide the 107-14 fountains over the horizontal tongues protruding from the mounting plate and fasten arms with set screws pushing slightly against the cover plate or finished wall.
8. Connect drain lines to two slip couplings, connect piping assembly from solenoid valve to fountain, install AA batteries and connect water to the stop valve.

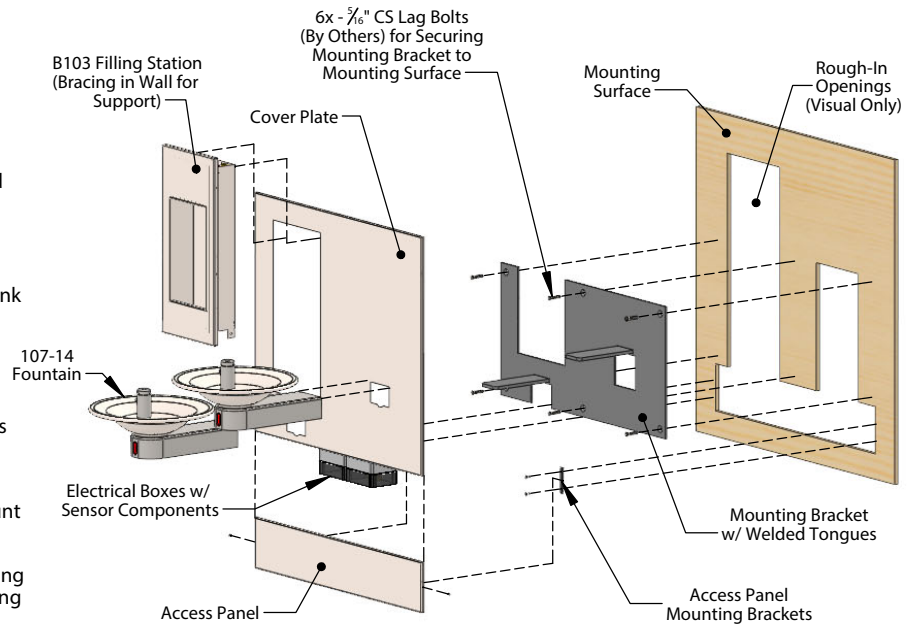

Access Panel Mounting Brackets Installation Details

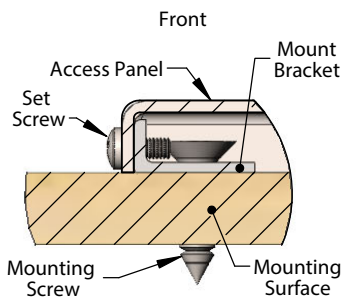

Detailed View of Top of Mounting Bracket Assembly

Typical Drain Plumbing Detail (In-Wall Plumbing Provided By Others, Install Per Local Code)

