

# Hands-Free Fountain Vandal Proof Bottle Filler Maintenance Instructions

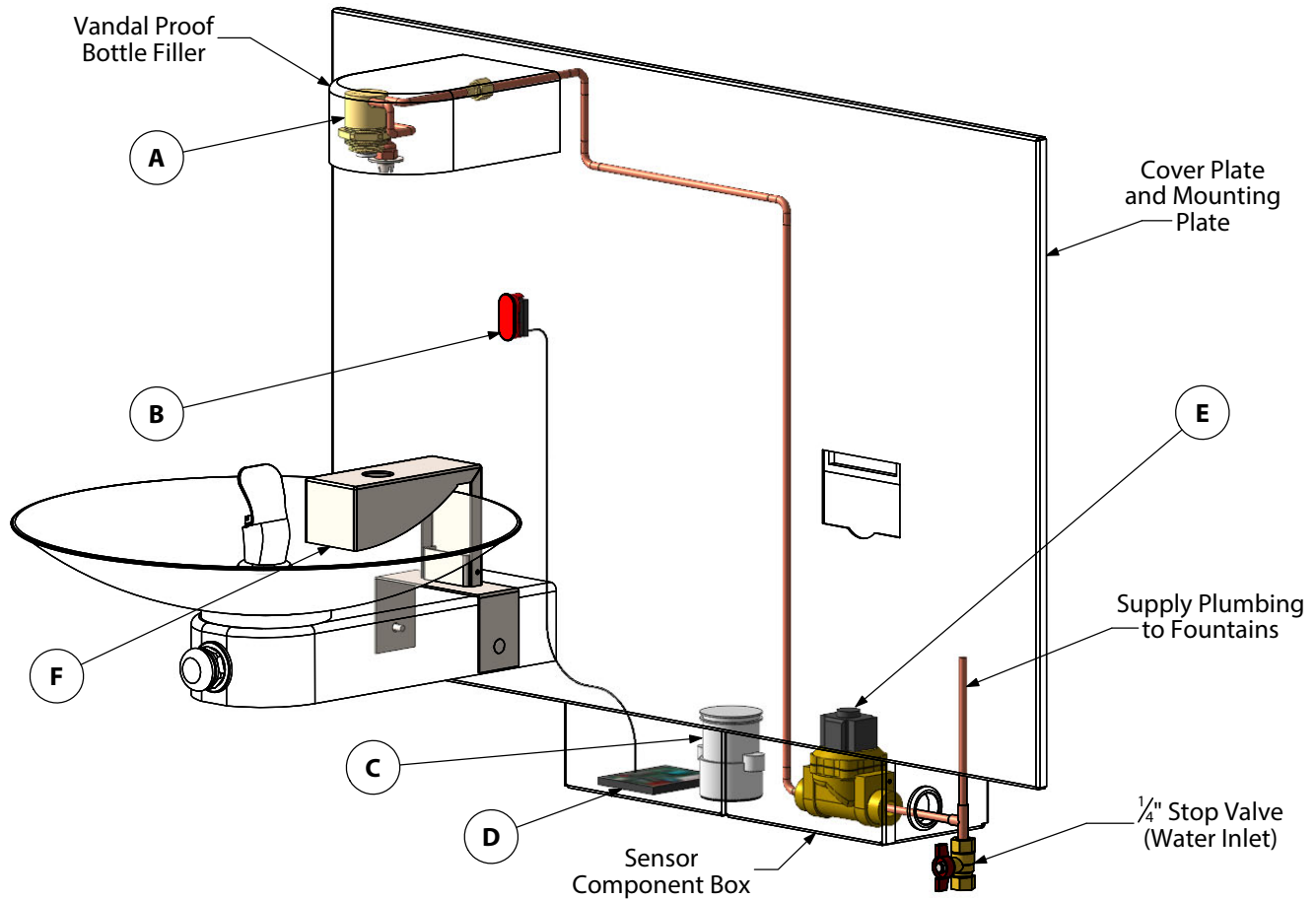

## Sensor Activated Bottle Filler Maintenance Instructions

### Water Flow Adjustment:

1. To adjust the flow of the bottle filler, remove security plate from bottom of arm with "snake eye" tool provided.
2. Turn white screw head on flow regulator cartridge clockwise with straight screwdriver to decrease flow and counterclockwise to increase flow.
3. To redirect bottle filler stream and reduce chance of splashing, insert tool provided into copper tube outlet bending it slightly toward the bowl drain or bottle rest opening if provided.

### Sensor Adjustment:

1. To adjust the distance of the sensor intensity, remove two jackman screws holding the 6" access panel below fountain or open the hinged access door under the fountain if provided.
2. Remove the cover from the sensor box as shown in assembly drawing.
3. Turn yellow phillips head screw on control module circuit board clockwise to lengthen distance and counter clockwise to shorten it.

DRAWING REFERENCE	DESCRIPTION	ORDER PART NO.
A	REGULATOR CARTRIDGE ASSEMBLY (FOR HANDS FREE BOTTLE FILLER)	45.0053
B	SENSOR	6.1714
	RED LENSE	6.1717
C	BATTERY BOX	6.1712
	AA LITHIUM BATTERIES - 4 PACK	51.0592
D	CONTROL MODULE	6.1716
E	SOLENOID VALVE	6.1708
F	BOTTLE REST	45.0227
ASSEMBLY	COMPLETE SENSOR KIT (PARTS 2-5)	6.1709

# Hands-Free Vandal Proof Bottle Filler Cartridge Regulator Replacement Instructions

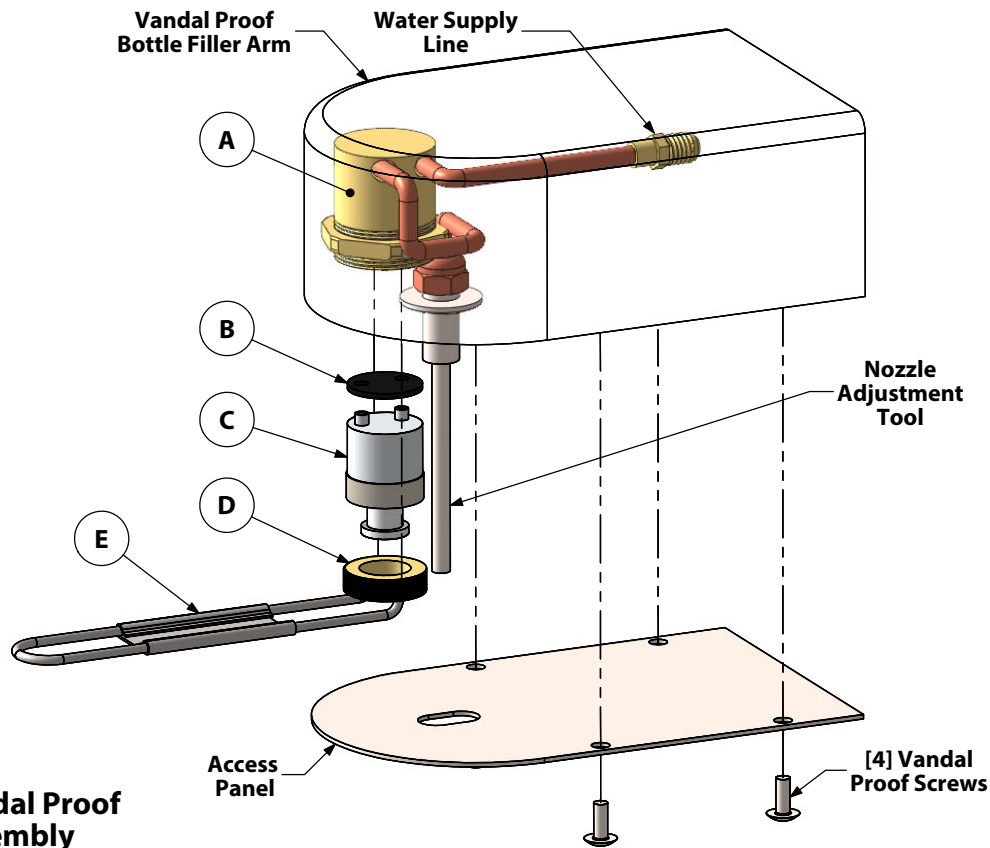

**Exploded View  
Hands-Free Vandal Proof  
Bottle Filler Assembly**

## Cartridge Regulator Replacement Instructions

1. Remove access panel on the underside of bottle filler arm.
2. Turn off water to the fixture and depress button to drain water left in the supply line.
3. Using spanner wrench or needle nose pliers, unscrew the brass regulator retaining ring.
4. Gently wiggle cartridge back and forth to free and remove it from the brass valve assembly body.
5. Check to ensure that the old neoprene seal was also removed from the valve assembly body.
6. Install new neoprene seal on the new cartridge regulator and install new assembly into the valve assembly body, ensuring inlet and outlet holes on the cartridge are lined up and the cartridge is seated properly in the valve body.
7. Reinstall the regulator retaining ring, and tighten using the spanner wrench or needle nose pliers.
8. Turn on water to fixture and test for flow and leaks by pushing plunger with flat screwdriver.
9. Reinstall access panel on the underside of bottle filler arm.
10. Insert  $\frac{1}{8}$ " dia. pipe provided or small screwdriver into copper nozzle of bottle filler. Adjust the pipe towards the middle of the bowl to reduce chance of splashing.

DRAWING REFERENCE	DESCRIPTION	ORDER PART NO.
A	VALVE ASSEMBLY BODY - BRASS	45.0157C
B	NEOPRENE SEAL	45.0053
C	REGULATOR CARTRIDGE ASSEMBLY (FOR HANDS FREE BOTTLE FILLER)	
D	REGULATOR RETAINING RING - BRASS	45.0008
E	SPANNER WRENCH	45.0017

# "Hands-Free" Sensor Activation Components

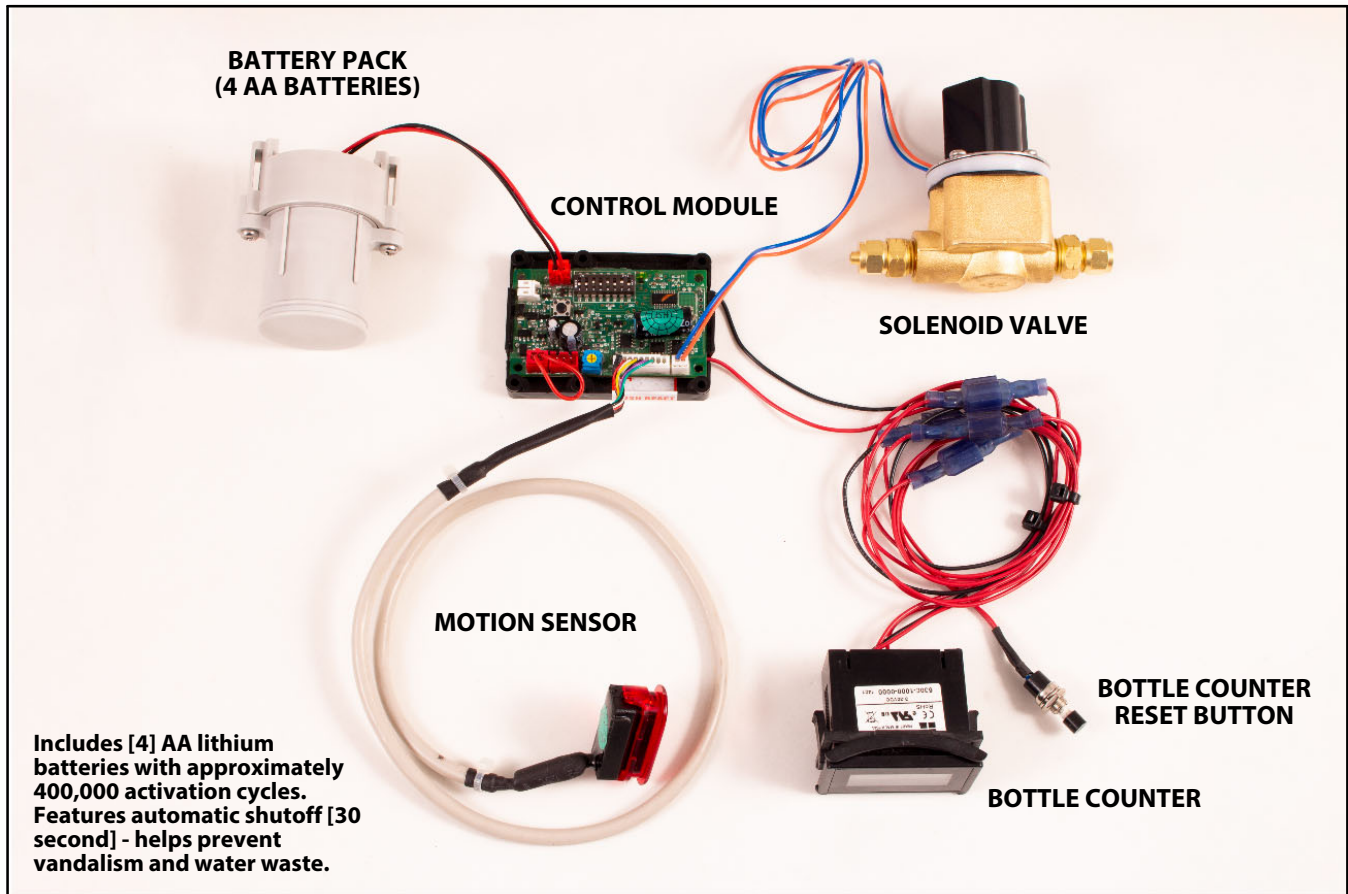

"Hands-Free" Control Module Diagram

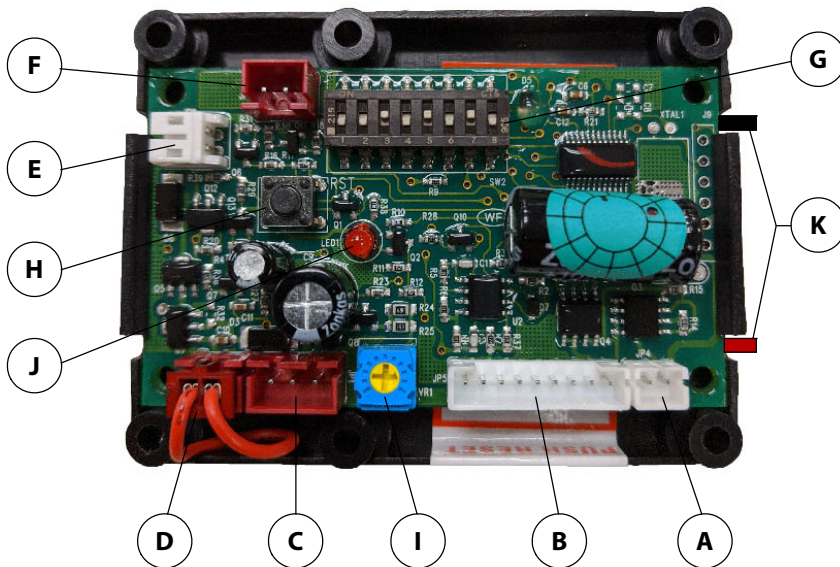

CONTROL MODULE LEGEND	
A	SOLENOID PIN RECEPTOR
B	CONTROL CABLE (SENSOR EYE) PIN RECEPTOR
C	AC INPUT PIN RECEPTOR
D	DC INPUT PIN RECEPTOR
E	ELECTRO-MECHANICAL PUSH BUTTON PIN RECEPTOR
F	BATTERY PACK INPUT RECEPTOR (DC)
G	DIP SWITCHES
H	RESET BUTTON
I	SENSOR DISTANCE ADJUSTMENT SCREW
J	RED LED LIGHT
K	CABLES TO BOTTLE COUNTER

**"Hands-Free" Control Module Instructions**

1. To adjust sensor length, turn the sensor adjustment screw (9)
2. Turn clockwise to lengthen the sensor distance
3. Turn counterclockwise to shorten the sensor distance