

# F-501-L and F-501-L-VP Water Bubblers Installation Assembly and Parts List



F-501-L Bubbler - Standard (STD) Mirrored Stainless Finish

## Bubbler Installation

- Before connecting the makeup water line to the fountain, open the supply line stop valve enough to give a good rush of water into a bucket. Repeat several times until the water runs clear. Start with the nearest fountain and progress one by one to the furthest down the supply line.
- When replacing a flow regulator the line should be flushed (as outlined above) to ensure proper operation of the new regulator.
- After flushing, install the regulator (see steps below) and snug the retaining ring by hand. It should be tightened only enough to make a water seal. Turn the supply stop valve fully on and check for leaks. Push the button on the regulator and check the stream height.
- Adjustments to the stream height should be slight (about 1/8 turn at a time). Turn clockwise to reduce flow and counter clockwise to increase flow. If the stream height doesn't change, check for flow restrictions elsewhere (i.e. stop valve not completely open, loose washer in stop valve, pinched piping, pipe dope or solder in piping, debris in screen at base of bubbler or spout). Air in the water can also cause erratic flow. Once the stream height is satisfactory, the finished hex nut and push button can be screwed onto the remaining threads of the retaining ring. Snug the hex nut with a padded wrench.

## Regulator Installation

- Ensure regulator cartridge is cleaned and assembled properly. See Water Regulator Assembly for instructions on assembling.
- Remove hexagon cover, push button and retaining ring.
- Insert regulator cartridge into body as shown and tighten with spanner wrench or needle nose pliers. **Do not over tighten, 3.5 lb/ft torque max!**
- Replace hexagon cover, push button and retaining ring in opposite order.

### BRONZE F-501-L LEVER BUTTON ORDER PART NOS.

		MIRRORED	STATUARY	SATIN	OIL RUBBED
F-501 ASSEMBLY	STD	45.1318	45.1418	45.1518	45.1618
	VP	45.1319	45.1419	45.1519	45.1619
BUTTON (C)		45.0345	45.0445	45.0545	45.0645
HEXAGON COVER (D)		45.0331	45.0431	45.0531	45.0631
SPOUT (E)		45.0330	45.0430	45.0530	45.0630

#### NOTE

Model F-501-L bubbler is "LEAD-FREE" per Manufacturers NSF Listing to ANSI/NSF Standard 61.

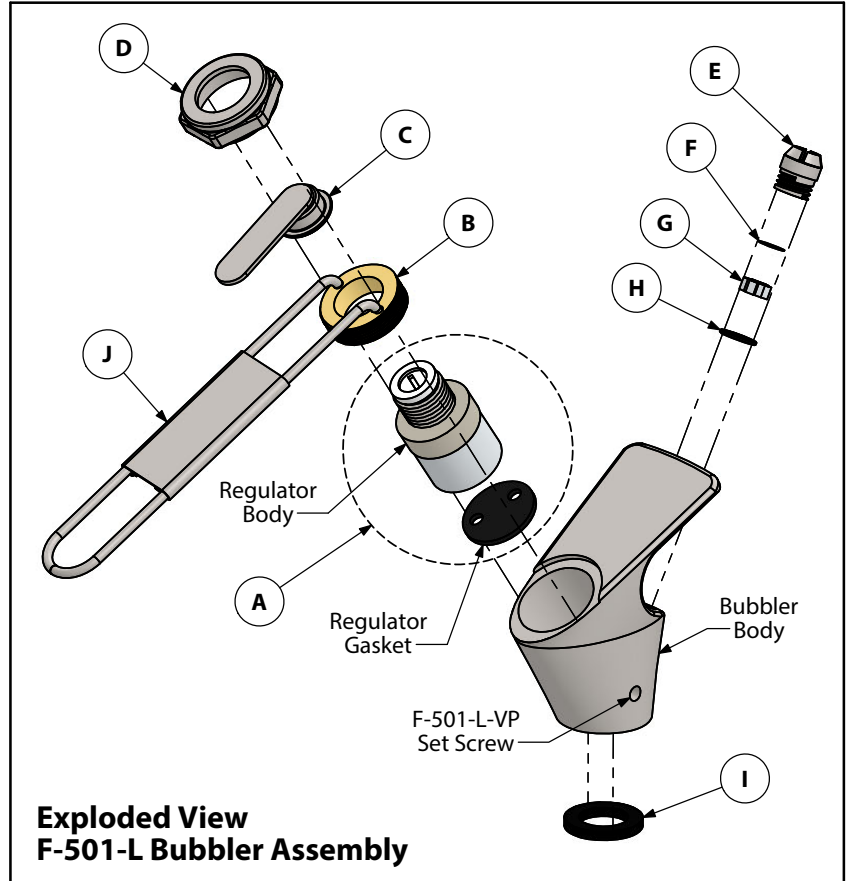

Exploded View  
F-501-L Bubbler Assembly

DRAWING REFERENCE	DESCRIPTION	ORDER PART NO.
ASSEMBLY	F-501-L S/S LEVER HANDLE PUSH BUTTON BUBBLER W/ ASSEMBLY	45.0018
	F-501-L S/S VANDAL PROOF ASSEMBLY	45.0072
A	REGULATOR CARTRIDGE ASSEMBLY	45.0006
B	RETAINING RING - BRASS	45.0008
C	LEVER HANDLE BUTTON - CHROME	45.0199
D	HEXAGON COVER - CHROME	45.0010
E	SPOUT - CHROME	SOLD AS UNIT 45.0011
F	SCREEN - STAINLESS STEEL	
G	STREAM STRAIGHTENER - BRASS	
H	O-RING - RUBBER	
I	MOUNTING WASHER - RUBBER	45.0016
J	SPANNER WRENCH	45.0017