



FCC-107-16-HL-VP-LS

Non-Recessed Vandal Proof High/Low Drinking Fountain with Cane Apron, In-Wall Chiller and Taste Master® Purifier



Optional Bottle Filler*, fountain support arm, cover plate, chiller cabinet, "Soft Touch" button valve*, and bubbler* shown in standard stainless steel satin finish

PRODUCT COMPLIANCE*

- ADA Compliance
- Buy America Act
- CA Proposition 65
- NSF/ANSI 42, 53 and 372 (Lead Free)
- UL STD 399
- CSA STD C22.2 #120

*More available on request

Options and finishes may differ from image shown.

**Hands Free" option available

Dimensions in drawing subject to options selected.

Features

- [2] 16" diameter, 16 ga. fountain Bowls
- No plastic parts
- 100% made in the USA
- Manufactured with lead-free materials
- Integral drain in bowl for ease of cleaning
- 1/4" steel support arm and wall bracket capable of supporting 500 lbs.
- Cover plate and access panel to match bowl finish or choose from unlimited powder coat colors
- 16 ga. plate secured with tamper-resistant screws for added security
- Pin-hinged, lockable door
- Options include sensor activation, bottle fillers, bottle counters, finishes, bubbler valves, and more...

Top View

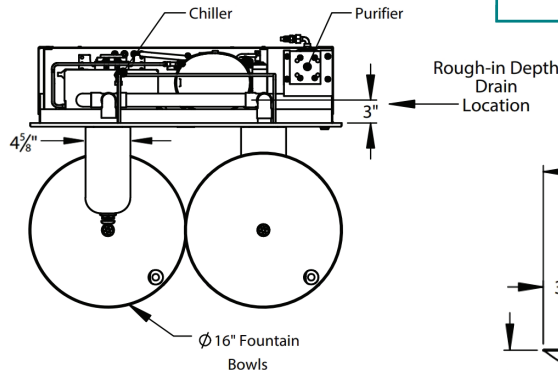

Front View

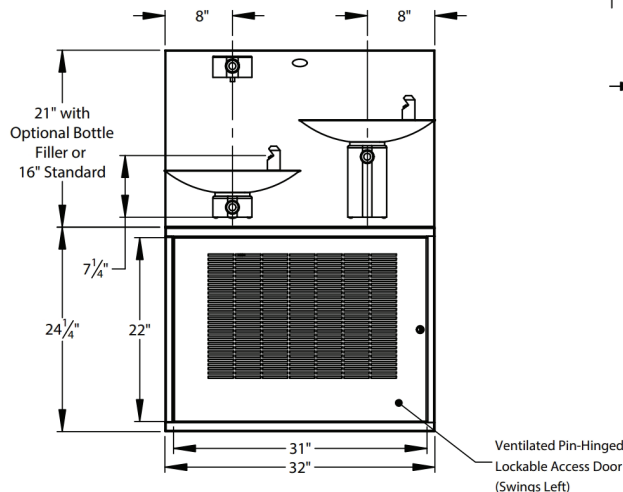

Select Low Fountain Location

- Left [S]
- Right

Side View

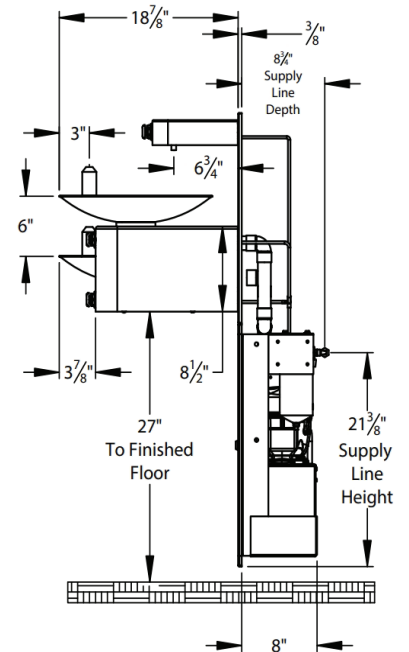

For options, finishes and more see page 2

FCC-107-16-HL-VP-LS Models Include: Chiller: Model 56A

- **Water In:** 1/4" FPT
- **Cooling Capacity:** 6 GPH @ 50° F [10° C]*
- **Storage:** 2 gal, insulated stainless steel tank
- **Refrigerant:** HFO R513A "Ozone Safe - Low GWP"
- **Electrical:** 120/60/1 or specify _____
*Higher capacity chillers are available, consult factory for correct model numbers.

Purifier: Taste Master® TMS1-0.5

- **Construction:** Stainless steel housing
- **Element:** Carbon block removes particulates, cysts, chlorine, organic odors and tastes. Exclusive seal design negates bypassing and leaking.

Filtrine Mfg. Co. • 15 Kit St. Keene, NH 03431 USA
800-930-3367 • 603-352-5500 • FAX 603-352-0330
www.filtrine.com • drinking_water@filtrine.com



FILTRINE IS ISO 9001:2015 CERTIFIED BY NSAI
PRODUCT LINE APPROVED MARK AVAILABLE



FCC-107-16-HL-VP-LS [EB]

REVISED
12.16.25



Filtrine Drinking Water Non-Recessed Fountain Options

[S] - Standard

- ADA Compliant

Standard Security Panel and Vandal Proof Bubbler [S]



"Soft Touch" Button and Projector Bubbler with Recessed Set Screws



16 ga. Plate Secured with Tamper-Resistant Screws for Added Security

Standard Bubbler Controls

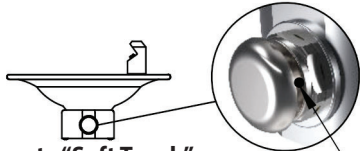

Remote "Soft Touch" Button Valve [S]

Tamper-Resistant Screws in Bubbler and "Soft Touch" Button(if applicable)

"Hands Free" Options



Bottle Counter*
• Digital display of approximate number of bottles saved through filler usage
*Only available with "Hands Free" units

Bottle Rest

• Located above fountain for reduced splash and one handed operation



"Hands Free" Sensor Activated Bottle Filler

- Features automatic shutoff (20 sec)
- Helps prevent vandalism and water waste

Power Supply Options:
(Choose only one)

- Connect 12v Transformer to A/C Power Supply [S] or
 - Use 12v Wall Plug
- 120/60/1 Voltage Required

"Hands Free" Sensor Activated Bubbler

Optional Bottle Fillers (Choose only one optional filler)

- Mounted 10½" above fountain bowl
- Requires larger cover plate
- Comes standard with tamper proof screws
- Supply plumbing for filler provided by Filtrine

"Soft Touch" Button Vandal Proof Filler*



*Hands Free options available

"Soft Touch" Button F-520 Bottle Filler*



*Hands Free options available

Other options are available, please contact the factory for more choices.

Vandal Proof Option: Yes [S] No

Bubbler Options:



F-507

All finish options available



F-501



F-501-L



F-502

Available in:
Stainless Steel,
Oil-Rubbed Bronze,
or Any Powder Coat
Options

Fountain Finish (Check One)

- Satin Stainless [S] Satin Bronze Statuary Bronze Oil-Rubbed Bronze Oil-Rubbed Bronze Powder Coat Powder Coat _____

Optional Cover Plate Finish (Check One)

- Satin Stainless [S] Satin Bronze Statuary Bronze Oil-Rubbed Bronze Oil-Rubbed Bronze Powder Coat Powder Coat _____



Satin Stainless Steel [S]

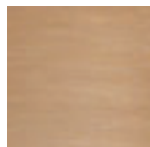

Satin Bronze

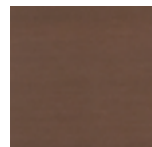

Statuary Bronze

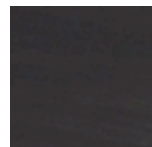

Oil Rubbed Bronze

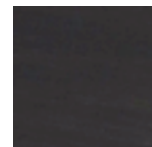

Oil Rubbed Bronze Powder Coat
(Applied to Stainless Steel)



Powder Coat

Filtrine Mfg. Co. • 15 Kit St. Keene, NH 03431 USA
800-930-3367 • 603-352-5500 • FAX 603-352-0330
www.filtrine.com • drinking_water@filtrine.com



FILTRINE IS ISO 9001:2015 CERTIFIED BY NSAI
PRODUCT LINE APPROVED MARK AVAILABLE



FCC-107-16-HL-VP-LS [EB]

REVISED
12.16.25

Mounting Plate Details (Front)

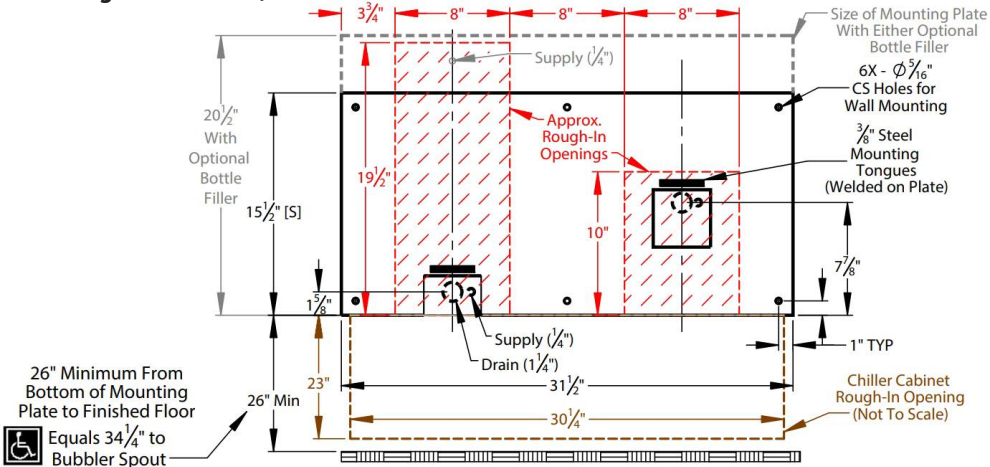

Mounting Plate Rough-In Dimensions (hatched, left)

MODEL	HEIGHT	WIDTH
107 Fountain	10"	8"
107 Fountain with Bottle Filler	19 1/2"	8"

*If unit does not have an optional bottle filler, make all rough-ins equal.

Access Panel Rough-In Dimensions (hatched, left)

MODEL	HEIGHT	WIDTH	DEPTH
Chiller Cabinet	23"	30 1/4"	8"

All views shown are for typical installation of FCC-107-16-HL-VP-LS. Views, dimensions and diagrams may change for specific installation requirements

Exploded On-Wall Installation View FCC-107-16-HL-VP-LS

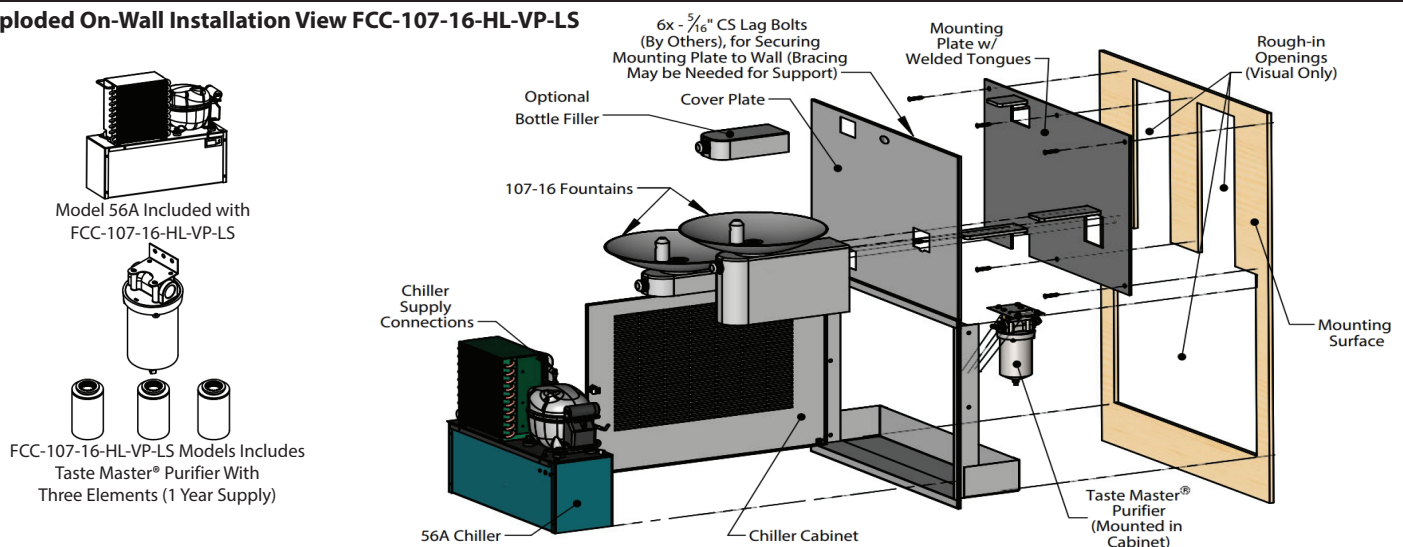

Typical Assembly Instructions (Always Install Per Local Code)

1. Cut rough opening per install requirements (rough opening example shown above) and install blocking or fixture carriers as required to support the drinking fountain mounting plate and purifier cabinet in a minimum 8" deep wall.
2. Cut a separate rough opening extending below the fountain mounting plate 23" high x 30 1/2" wide maximum rough in opening dimensions.
3. Fasten mounting plate over rough opening with 5/16" countersunk lag bolts with bottom of plate 26" above floor to meet ADA fountain height requirement of 34 1/4" to the bubbler spout.
4. Install chiller cabinet in rough opening below the mounting plate and slide the cover plate over the mounting plate. Using screws, fasten the cabinet to the mounting surface through the side flange of the cabinet.
5. Slide the fountain arms over the horizontal tongues protruding from the mounting plate and fasten with set screws pushing slightly against the cover plate.
6. Install chiller into the cabinet, making sure the side with the electronic temperature controller is facing the door. Do not plug in chiller until Step 10 is completed and tank is full of water.
7. Connect supply line to 1/4" FPT connection at stop valve at the purifier.
8. Connect drain line to slip coupling unions. Use plumber's tape and crescent wrench to ensure all connections are tight. Connect drain trap per local code.
9. Install filter cartridge in housing per instructions on filter.
10. Activate bubbler with push button or sensor until all air in cooler tank and piping is purged out. If required, adjust flow regulator with screw driver per instructions in manual.
11. Plug cooler into a 15 amp GFCI circuit after the tank and piping system are completely full of treated water.

Chiller Cabinet Installation Details

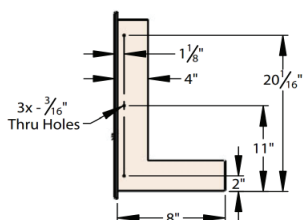

Typical Drain Plumbing Detail (In-Wall Plumbing Provided by Others, Install Per Local Code)

