

HF-90-RFK DIY "Hands Free" Bowl Retrofit Kit for Model 107 Fountains

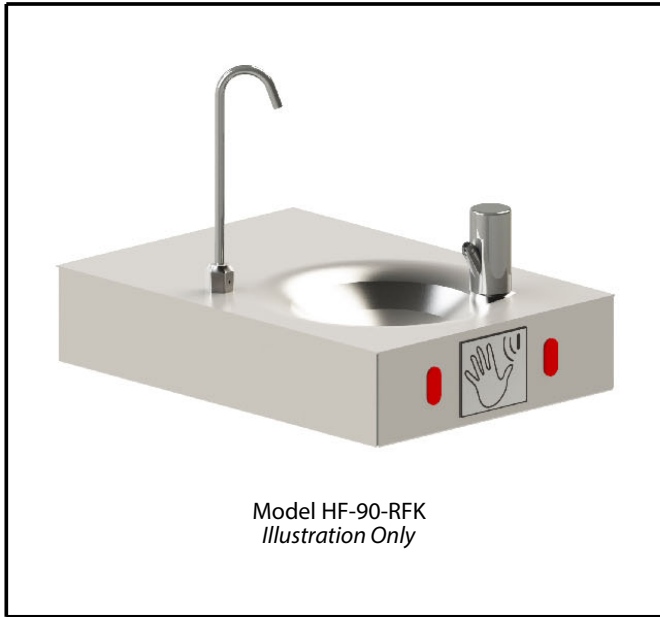

Model HF-90-RFK
Illustration Only

Features

"Hands Free" Model 90 bowl(s) slides over existing Model 107 drinking fountain tongue(s).

Features include:

- Easy DIY installation, no need to hire a plumber
- "Hands Free" sensor and components installed in base in self contained unit
- Components include: sensor, electrical box, battery pack, control module, cartridge regulator and [4] lithium AA batteries* providing approximately 400,000 activation cycles
- "Hands Free" and "Waving Hand" permanent labels



*115v AC option available

Finish Options

"Hands Free" fountain/bubbler

Stainless Steel [S]:

- Satin [S] Mirrored
 Powdercoat: _____

Bronze:

- Satin Statuary
 Mirrored Oil-Rubbed

Existing Fountain Model:

- Single Bowl Dual Bowl
 Triple Bowl Quad Bowl

Bottle Filler Option

- Bottle Filler mounts on top of low bowl. Operated by a second "Hands Free" sensor on the front face of the fountain (see Front View)

[S] = Standard

HF-90-RFK Installation Instructions

1. Disconnect drain and supply connections of existing fountain. Unscrew bolts that hold mounting tongue to Model 107 arm bracket. Remove Model 107 bowl and arm off of mounting tongue and away from cover plate.
2. Install Model HF-90-RFK, sliding the bracket on the bottom over the mounting tongue and pressing the back side against the cover plate. Fasten the screws into the bracket and tongue to secure fountain.
3. Connect drain plumbing to 1/4" slip coupling and supply plumbing to 1/4" female flare nut.
4. Install batteries into battery pack and place hand in front of sensor to test sensor distance and flow rate.

Sensor Adjustment: To adjust the distance of the sensor intensity, turn the yellow phillips head screw on the control module circuit board clockwise to lengthen distance and counter clockwise to shorten it.

Water Flow Adjustment: To adjust the bubbler water flow, turn the white screw head on the the flow regulator cartridge. To decrease flow, screw head clockwise. To increase flow, screw head counterclockwise.

"Hands Free" Sensor Replacement Parts

DRAWING PART NO.	DESCRIPTION	ORDER PART NO.
1	CARTRIDGE REGULATOR (FOR HANDS FREE BUBBLER)	45.0053
2	SENSOR	6.1714
	RED LENSE	6.1717
3	BATTERY BOX	6.1712
	AA LITHIUM BATTERIES - 4 PACK	51.0592
4	CONTROL MODULE	6.1716
5	SOLENOID VALVE	6.1708
ASSEMBLY	COMPLETE SENSOR KIT	6.1709

Top View

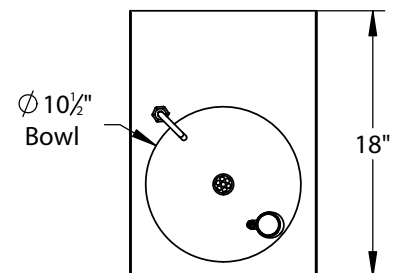

Front View

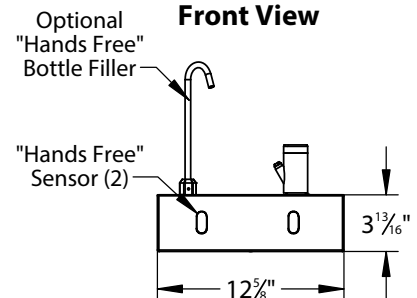

Bottom View

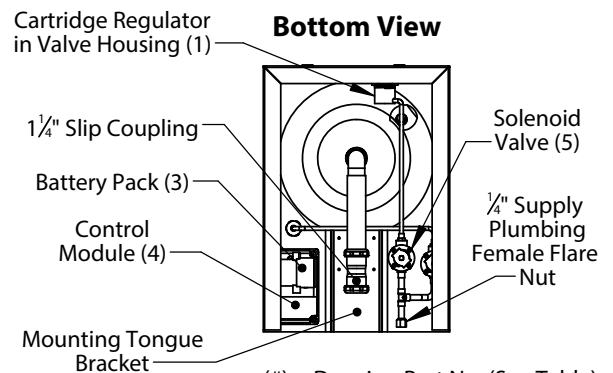

(#) = Drawing Part No. (See Table)