

# QUICK CONNECT PANEL

USE WITH FILTRINE CHILLERS - INDOOR INSTALLATION ONLY

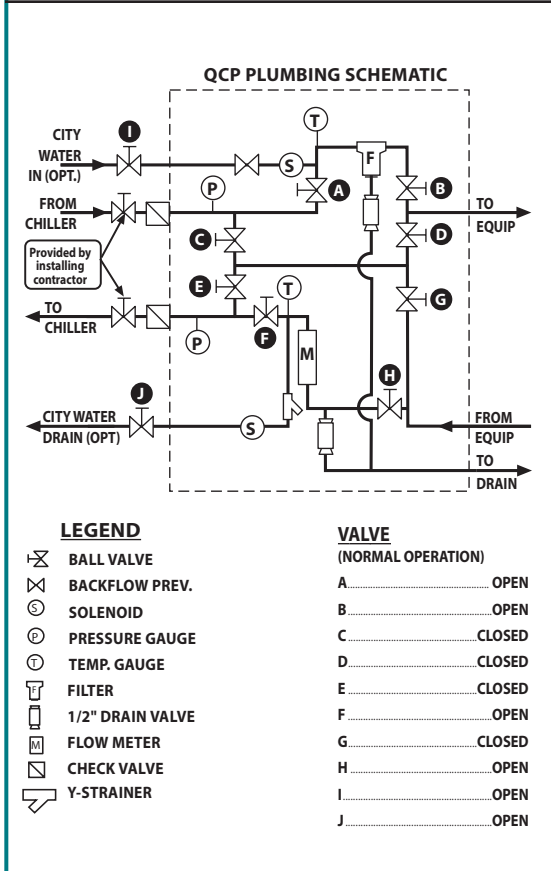

TYPICAL QCP



## MODEL..... QCP-1.0

**Includes these features:**

- In-Line Filter
- Pressure Gauges
- Temperature Gauges
- Flow Meter

A properly operating Filtrine medical chiller is essential for the operation of your medical equipment such as MRI, CT or linear accelerators. This panel provides diagnostic information on the Filtrine chiller so that you can see at glance if it is operating correctly and carry out maintenance, if required, to prevent down-time. Filtrine has selected and installed these gauges, etc., in consultation with medical equipment manufacturers so that you can be sure they supply this vital information.

This compact panel is installed between the Filtrine chiller and medical equipment for instantaneous availability of autoswitchover to city water [optional], pressure gauges, temperature gauges, flow meter and in-line filter. Panel is complete with all valves, solenoids, bypass and service drains installed.

### CABINET

Constructed of enameled aluminum panels, with stainless steel top and sides. Panel is removable without tools for access to valves and filter. Dimensions are 30" [30 mm] W x 10" [254 mm] D x 36" [915 mm] H.

### TEMPERATURE GAUGES

For water entering and leaving equipment are dial-type, in Celsius and Fahrenheit, uses probe for maximum accuracy with no pressure drop.

### PRESSURE GAUGES

Dial-type, in psi and bar and generate no pressure drop.

### FLOW METER

Analog type with moving indicator in liters and gallons per minute, for minimum pressure drop.

### FILTER

Bag-type, using 50 micron bag with less than 1 psi pressure drop when new. Filter located inside the panel; includes bypass piping to ensure easy filter element change.

### OVERALL PRESSURE DROP

Through panel at 20 gpm flow is under 10 psi when filter is clean.

### CONNECTIONS

CHILLER SIDE.....1" FPT [25 mm] copper pipe\*  
EQUIPMENT SIDE..... 1-1/4" FPT [32 mm]  
SERVICE DRAIN.....1/2" FPT [12.5 mm]  
\* Other sizes available

**UNIT WEIGHT** ..... 250 lbs. [113 Kg]

### OPTIONS AVAILABLE

**AS AUTOSWITCHOVER TO CITY WATER:** Cooling is already piped for easy access to backup cooling. Power supplied from chiller is 115/60/1. Switchover occurs on high temperature, low flow and power loss alarms.

**HT HIGH TEMPERATURE INTERLOCK:** Signals warning light when coolant temperature exceeds high limit.

**LF LOW FLOW INTERLOCK:** Signals warning light upon loss of coolant flow [pump failure].

**UPS BATTERY BACKUP:** Helps prevent loss of glycol due to nuisance tripping during short power failure, brownout or generator testing.

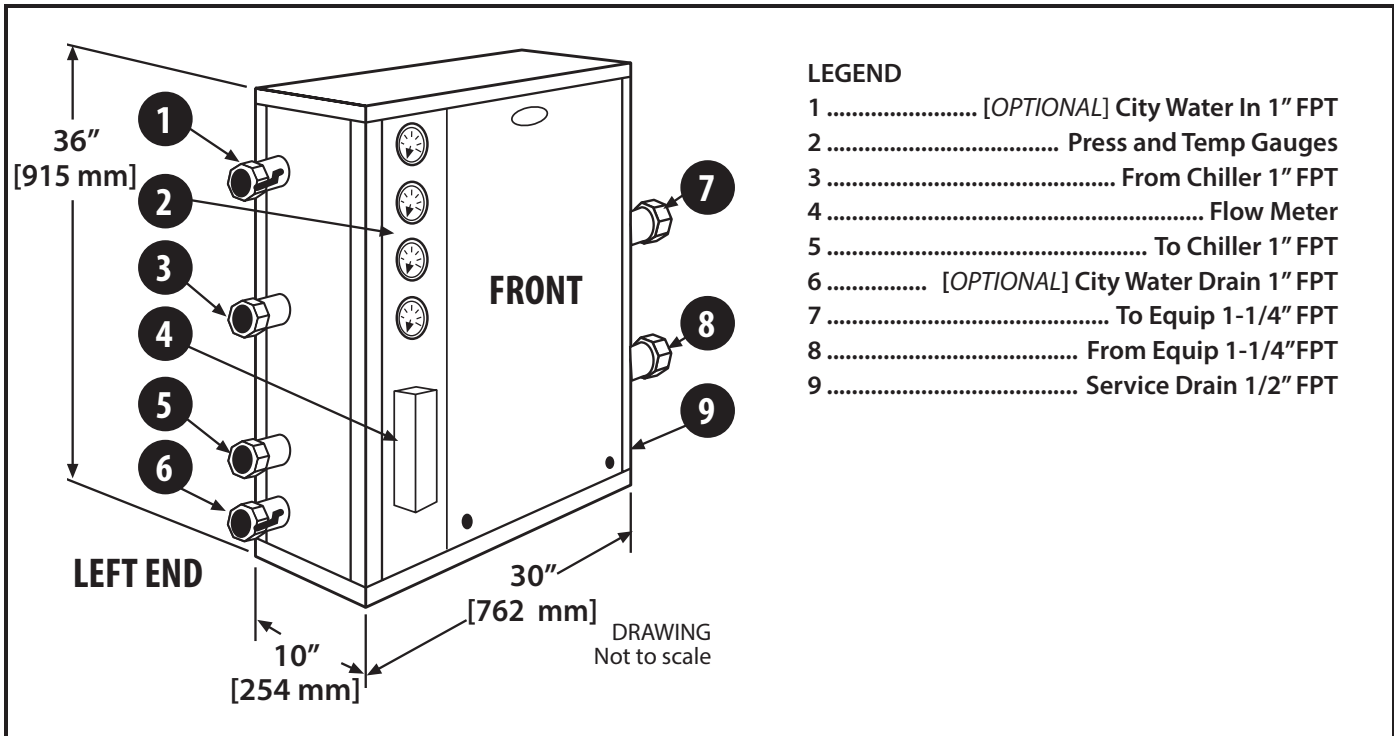

**INTERCONNECT TERMINALS TO CHILLER**

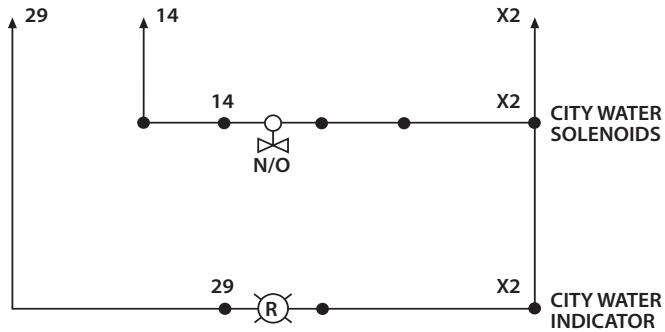

**MOUNTING BRACKET**

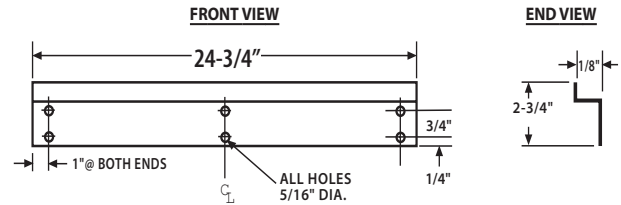

**WARRANTY**

All parts are covered FOB jobsite for 12 months from the start date or 15 months date of shipment or whichever comes first.

