



FCC-107-14-HHL-VP

Non-Recessed, Vandal Proof Tri-Bowl Drinking Fountain with In-Wall Chiller and Taste Master® Purifier



Fountain bowl, cover plate and chiller cabinet shown in standard stainless steel satin finish with "Soft Touch" button valves, bubblers and vandal proof bottle filler in mirror finish

Dimensions in drawing subject to options selected.

Features

- [3] 14" diameter, 16 ga. fountain bowls
- No plastic parts
- 100% made in the USA
- Manufactured with lead-free materials
- Integral drain in bowl for ease of cleaning
- 1/4" steel support arm and wall bracket capable of supporting 500 lbs.
- Matching cover plate and cabinet finishes including unlimited powder coat colors
- Options include vandal proof bubblers, bottle fillers, bottle counters, finishes, bubbler valves, and more...

Top View

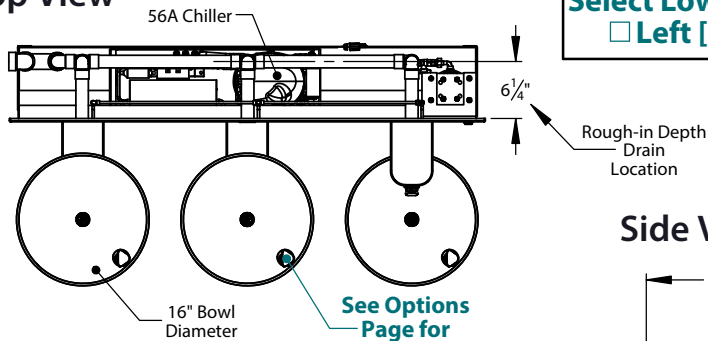

Select Low Fountain Location
 Left [S] Right

See Options Page for Bubbler Types

Side View

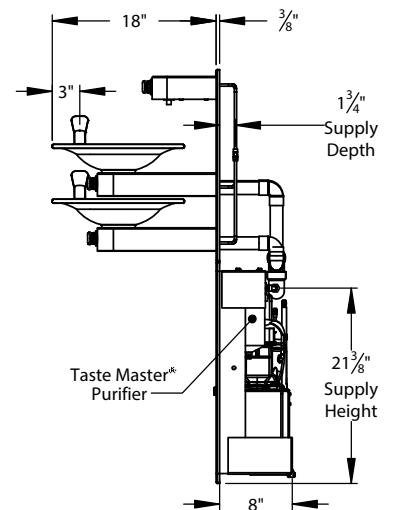

Front View

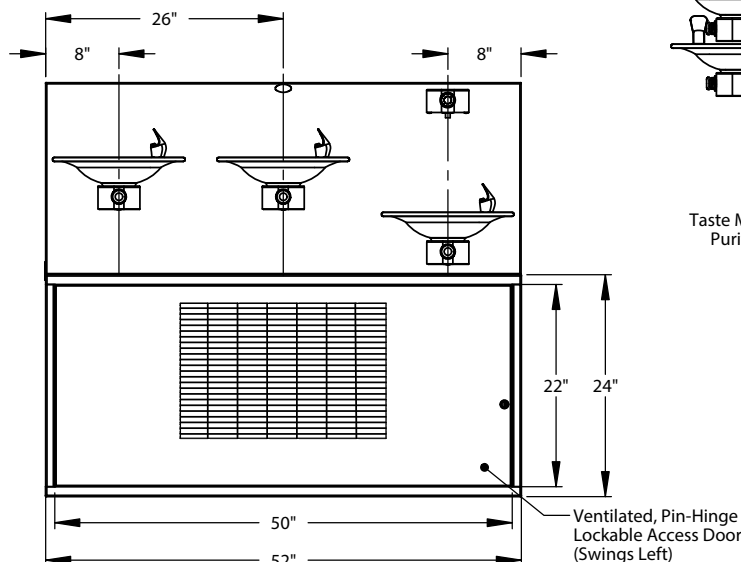

For options, finishes and more see page 2

FCC-107-14-HHL-VP Models Include:

Chiller: Model 56A

- Water in: 1/4" FPT
- Cooling Capacity: 6 GPH @ 50°F [10°C]*
- Storage: 2 gal, insulated stainless steel tank
- Refrigerant: HFO R513A "Ozone Safe - Low GWP"
- Electrical: 115/60/1 or specify _____

*Higher capacity chillers are available consult factory for correct model #s.

Purifier: Taste Master® TMS1-0.5

- Construction: Stainless steel housing
- Element: Carbon block removes particulates, cysts, chlorine, organic odors and tastes. Exclusive seal design negates bypassing and leaking.





Vandal Proof Non-Recessed Fountain Options

[S] - Standard
☑ - ADA compliant

Standard Vandal Proof Bottle Filler

Features:

- Mounted 10½" above lowest fountain bowl
- Comes standard with bottom security panel assembled with tamper proof screws and "Soft Touch" button valve
- Supply plumbing and mounting tongue for filler provided by Filtrine



"Soft Touch" Button Valve with Recessed Set Screw

Bubbler Control Options (Check One)



Integral "Easy Touch" Lever Valve



Integral "Push Button" Valve

Recessed Set Screw

Standard Security Panel and Vandal Proof Bubbler

"Soft Touch" Button and Projector Bubbler with Recessed Set Screws



16 ga. Plate Secured with Tamper-Resistant Screws for Added Security

4x Tamper-Resistant Screws



Standard 21" High Cover Plate

- 16 gauge metal construction
- Material and finish for cover plate can be selected below

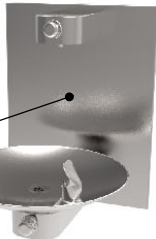

Cover Plate Friction Fit on Mounting Plate

Bottle Filler Options

"Hands Free" Sensor Activated

- 4x -AA lithium batteries (included)
- Runs approximately 400,000 cycles
- Features automatic shutoff (30 sec)
- Includes 6" access panel below fountain for sensor controls (see below)

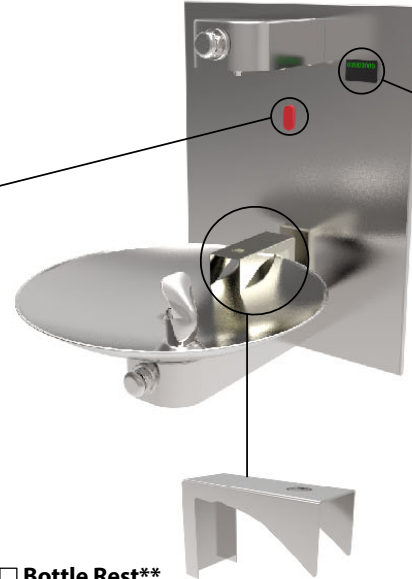

Bottle Counter*

- Digital display of approximate number of bottles saved through filler usage
- * Only available with sensor activation

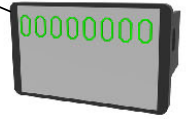

Bottle Rest**

- Located above lowest fountain for reduced splash and one handed operation
- **Recommended with sensor activation

Fountain Finish (Check One)

- Satin Stainless [S] Mirrored Stainless Satin Bronze Mirrored Bronze Statuary Bronze Oil-Rubbed Bronze

Cover Plate Finish (Check One)

- Satin Stainless [S] Mirrored Stainless Powder Coat _____ Satin Bronze Mirrored Bronze Statuary Bronze Oil-Rubbed Bronze

Stainless



Satin Stainless Steel [S]



Mirrored Stainless Steel

Bronze

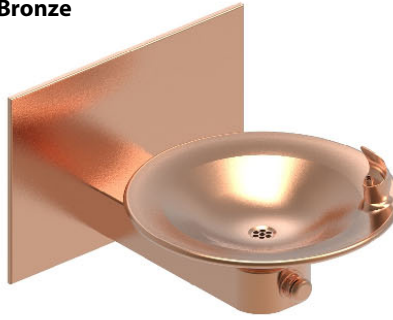

Satin Bronze

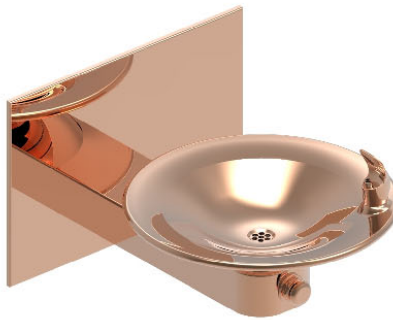

Mirrored Bronze



Oil Rubbed Bronze



Statuary Bronze





Model FCC-107-14-HHL-VP Drinking Water Installation Drawing

Mounting Plate Details (Front)

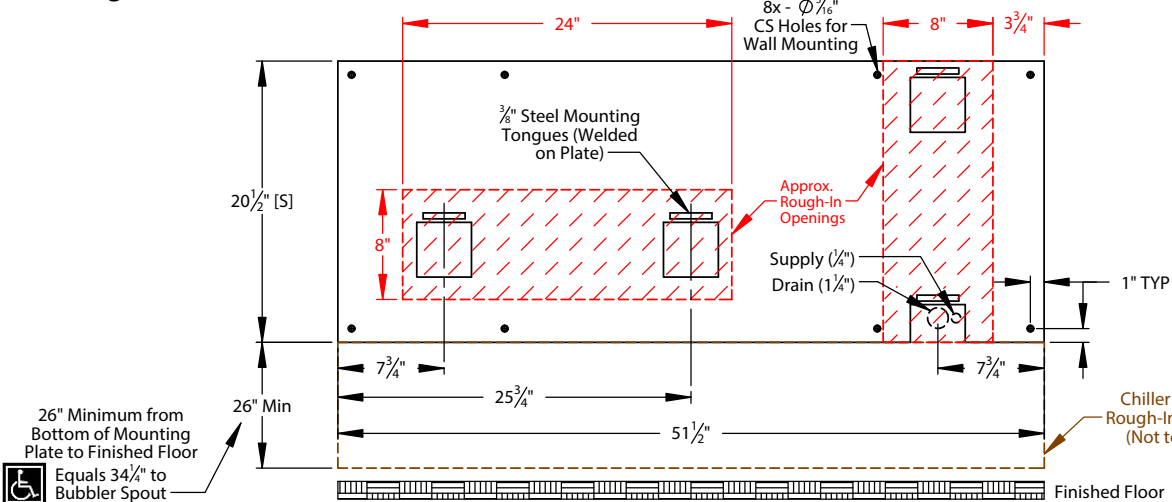

Approximate Rough-In Dimensions (hatched, left)

Model	Height	Width
Standard Plate	15 1/2"	8"
Bottle Filler Plate	20 1/2"	8"

Approximate Chiller Cabinet Rough-In Dimensions (outlined, left)

Model	Height	Width
Standard Cabinet*	23"	50 1/2"

*If height specified, rough-in height will be 1/2" less than specified height

All views shown are for typical installation of FCC-107-14-HHL-VP. Views, dimensions and diagrams may change for specific installation requirements

FCC-107-14-HHL-VP Exploded and Dimensions Installation Views

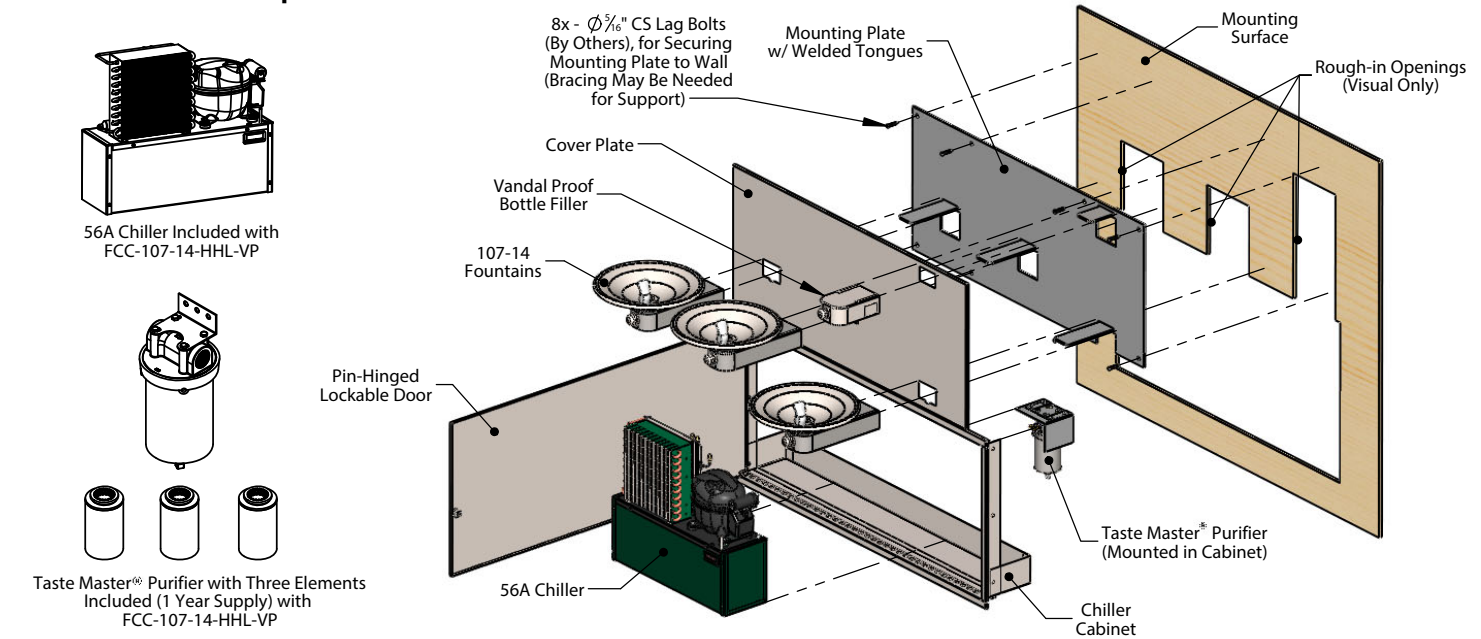

Typical Assembly Instructions (Always Install Per Local Code)

1. Cut fountain rough openings per install requirements (rough opening example shown above) and install blocking or fixture carriers as required to support the drinking fountain mounting plate and chiller cabinet in a minimum 10" deep wall.
2. Cut a separate rough opening extending below the fountain mounting plate, 23" high x 50 1/2" wide maximum rough in opening dimensions.
3. Run drain piping to center of openings on mounting plate (dimensioned above), and install drain trap(s) in wall per local code.
4. Run supply water line to mounted Taste Master® filter housing.
5. If optional bottle filler is included with order, attach piping assembly provided by Filtrine to the back side of the mounting plate with two screws and rubber gasket for standard bottle filler and flare connection for vandal proof bottle filler.
6. Fasten mounting plate to mounting surface over rough opening with 5/16" countersunk lag bolts with bottom of plate 26" above the floor to meet ADA fountain height requirement of 34 1/4" to the bubbler spout.
7. Install chiller cabinet in rough opening below the mounting plate using 5/16" holes in the side flange of the cabinet. Chiller cabinet should be located approx. 1/4" below and centered with the mounting plate above.
8. Install cover plate over mounting plate, and slide each fountain and vandal proof bottle filler arm (if ordered) over the horizontal tongues protruding from the mounting plate and fasten arms with set screws pushing slightly against the cover plate.
9. Connect drain line to slip coupling at each fountain and connect supply line to filter housing.

Chiller Cabinet Mounting Detail

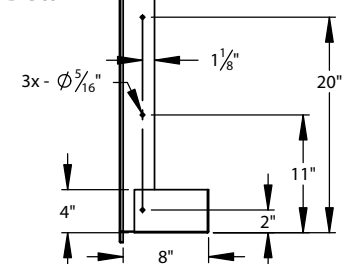

Typical Drain Plumbing Detail (In-Wall Drain Plumbing Provided By Others, Install Per Local Code)

