



90MOD-HL-VP

Non-Recessed Vandal Proof High/Low Drinking Fountain



Fountain support arm, optional bottle filler, access panel, "Soft Touch" button valve*, and bubbler* shown in standard stainless steel satin finish

PRODUCT COMPLIANCE*

ADA Compliance
Buy America Act
CA Proposition 65
Components: CA NSF/ANSI 372 (Lead Free)
**More available on request*

*Hands Free" option available

Options and finishes may differ from image shown.

Dimensions in drawing subject to options selected.

Features

- [2] 10½" diameter, 16 ga. fountain Bowls
- No plastic parts
- 100% made in the USA
- Manufactured with lead-free materials
- Integral drain in bowl for ease of cleaning
- Continuous weld construction leaving no visible seams
- Cover plate and access panel to match bowl finish or choose from unlimited powder coat colors
- 16 ga. plate secured with tamper-resistant screws for added security
- Standard 6" access panel
- Options include sensor activation, bottle fillers, finishes, bubbler valves, and more...

Recommended Add-ons

Chiller

Equip your fountain with a Filtrine point-of-use or remote chiller to cool your drinking water. We can help you select the most economic chiller model to fit your demand.

Purifier

Ensure that your drinking water is of the highest quality by adding a Filtrine Taste Master® purifier cabinet underneath the fountain or a remote purification system serving all fountains in the building.

Top View

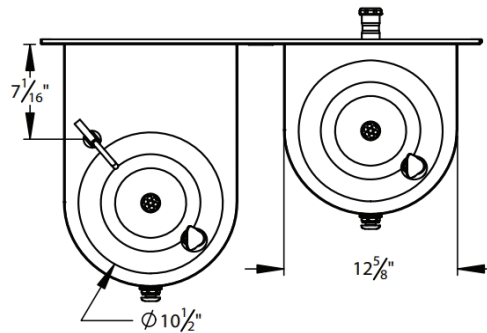

Select Low Fountain Location

- Left [S] Right

Side View

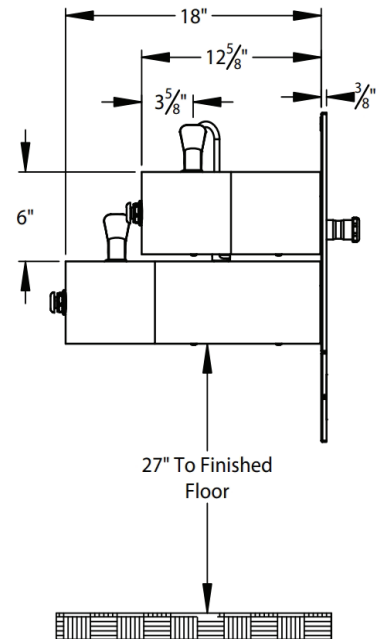

Front View

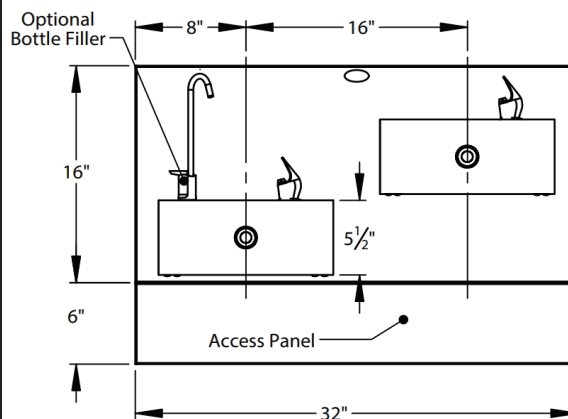

For options, finishes and more see page 2





Filtrine Drinking Water Non-Recessed Fountain Options

[S] - Standard

- ADA Compliant

Standard Security Panel and Vandal Proof Bubbler [S]



"Soft Touch" Button and Projector Bubbler with Recessed Set Screws

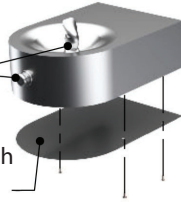

16 ga. Plate Secured with Tamper-Resistant Screws for Added Security

Standard Bubbler Controls

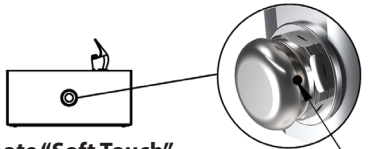

Remote "Soft Touch" Button Valve [S]

Tamper-Resistant Screws in Bubbler and "Soft Touch" Button (if applicable)

Fountain Options

Bottle Filler Options
(Choose One)

CC-153-STV "Hands Free" Sensor Activated Bottle Filler

CC-153 "Push Back" Lever Bottle Filler [S]
See Below

No Bottle Filler



"Hands Free" Sensor Activated Bubbler

- Features automatic shutoff (20 sec)
- Helps prevent vandalism and water waste

Power Supply Options:
(Choose only one)

- Connect 12v Transformer to A/C Power Supply [S] or
 - Use 12v Wall Plug
- 120/60/1 Voltage Required

Optional Bottle Fillers (Choose only one optional filler)

- Mounted on fountain bowl
- Durable, stainless steel design
- Comes standard with tamper proof screws
- Supply plumbing for filler provided by Filtrine

Model CC-153 "Push Back" Lever Valve [S]



Model CC-153-STV Valve



Other options are available, please contact the factory for more choices.

Access Panel: 6" Access Panel [S] No Access Panel Custom Access Panel: _____"

Vandal Proof Option: Yes [S] No

Bubbler Options:



F-507

All finish options available



F-501



F-501-L



F-502

Available in:
Stainless Steel,
Oil-Rubbed Bronze,
or Any Powder Coat
Options

Fountain Finish (Check One)

Satin Stainless [S] Satin Bronze Statuary Bronze Oil-Rubbed Bronze Oil-Rubbed Bronze Powder Coat Powder Coat _____

Optional Cover Plate Finish (Check One)

Satin Stainless [S] Satin Bronze Statuary Bronze Oil-Rubbed Bronze Oil-Rubbed Bronze Powder Coat Powder Coat _____



Satin Stainless Steel [S]

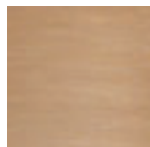

Satin Bronze

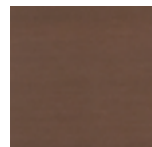

Statuary Bronze

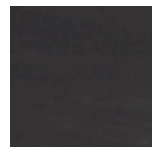

Oil Rubbed Bronze

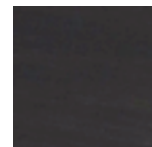

Oil Rubbed Bronze Powder Coat
(Applied to Stainless Steel)



Powder Coat

Filtrine Mfg. Co. • 15 Kit St. Keene, NH 03431 USA
800-930-3367 • 603-352-5500 • FAX 603-352-0330
www.filtrine.com • drinking_water@filtrine.com



FILTRINE IS ISO 9001:2015 CERTIFIED BY NSAI
PRODUCT LINE APPROVED MARK AVAILABLE



90MOD-HL-VP [EB]

REVISED
03.06.26

Mounting Plate Details (Front)

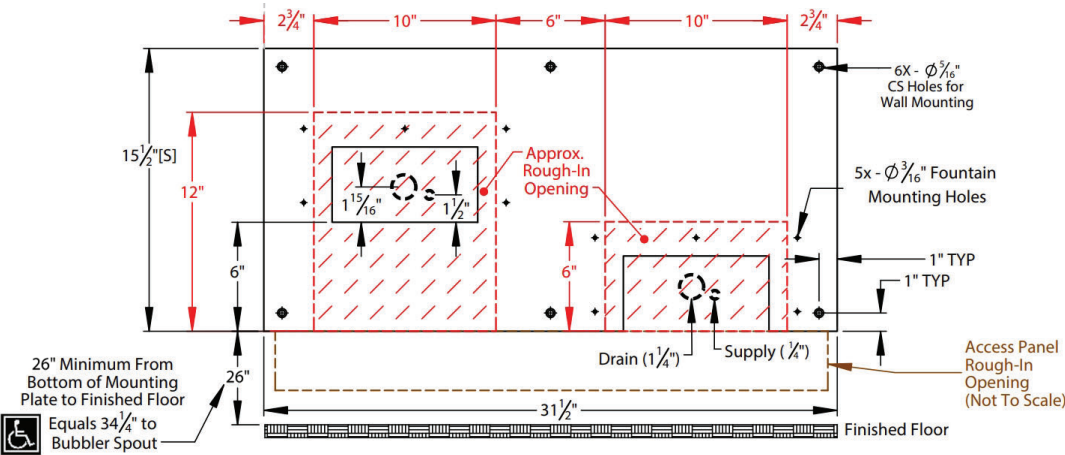

Mounting Plate Rough-In Dimensions (hatched, left)

MODEL	HEIGHT	WIDTH
High Bowl	12"	10"
Low Bowl	6"	10"

Access Panel Rough-In Dimensions (hatched, left)

MODEL	HEIGHT	WIDTH
Standard Panel	5 1/2"	30 1/2"

All views shown are for typical installation of 90MOD-HL-VP.

Views, dimensions and diagrams may change for specific installation requirements

Exploded On-Wall Installation View: 90MOD-HL-VP

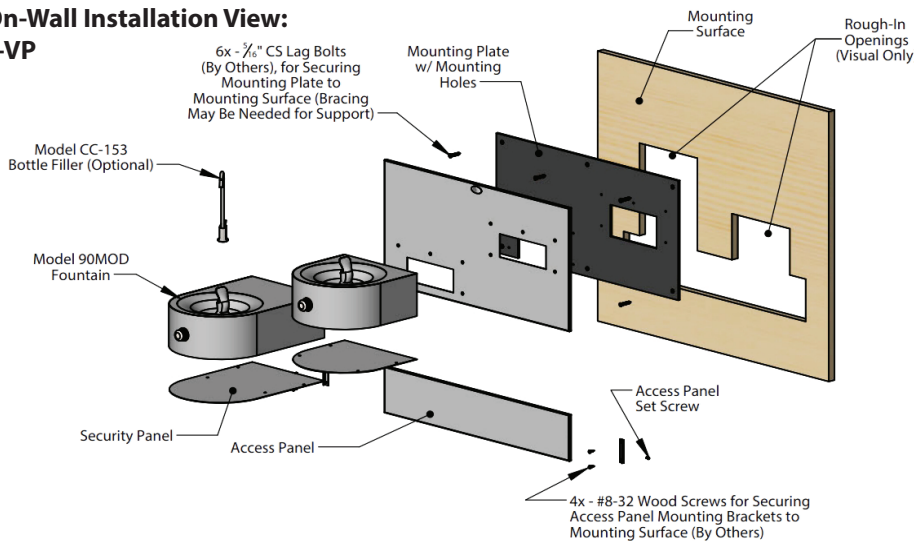

On-Wall Mounting Detail With Cover Plate

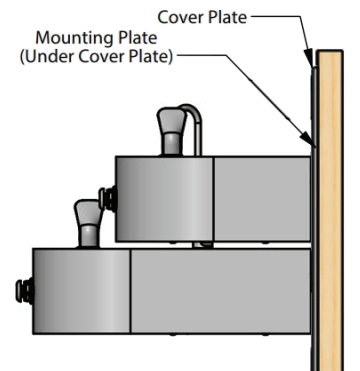

Behind-Wall Mounting Detail Without Cover Plate

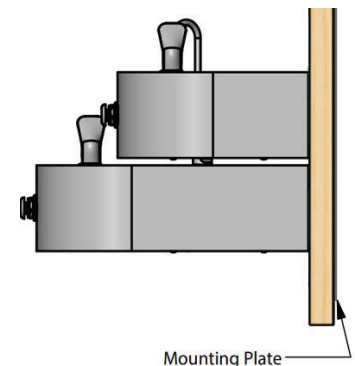

Typical Assembly Instructions (Always Install Per Local Code)

1. Cut rough opening for fountain and access panel as shown above and install blocking or fixture carrier as required to support the assembly.
2. Run drain pipe to slip coupling unions (shown below) and install drain trap in wall per local code.
3. Run supply water with service valve, if necessary (shown below).
4. Fasten mounting plate over rough opening with 5/16" countersunk lag bolts with bottom of plate 26" above the floor to meet ADA fountain height requirement.
5. Install cover plate over the mounting plate for on-wall installations.
6. Secure the fountain bowls to the mounting plate using the screws provided.
7. Connect drain line to slip coupling and connect water connection.
8. If ordered, attach security plate to bottom of fountain arms using vandal proof screws provided.
9. If your model includes the access panel, measure, mark and install the included "L" brackets with #8-32 screws and align panel to cover plate with alignment pins.

Access Panel Mounting Brackets Installation Details

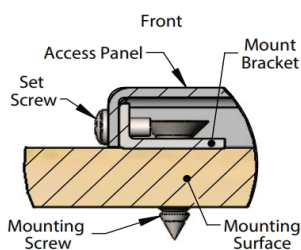

Typical Drain Plumbing Detail (In-Wall Plumbing Provided by Others, Install Per Local Code)

Back View (Cropped)

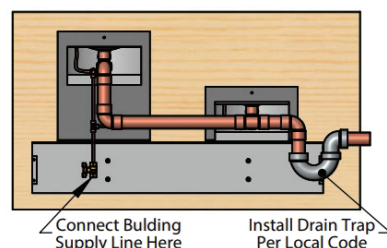

Top View

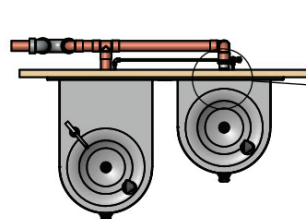

Plumbing Connections

