

# Custom Engineered Chillers For Medical Imaging Equipment



Made in USA

# **FILTRINE** chillers are engineered for high-performance medical equipment

**FILTRINE**... as a company with more than a century of experience, we are understandably proud of our long-standing reputation for engineering and building high-quality, application specific products.

**FILTRINE** is recognized around the world as the provider of innovative solutions for liquid cooling as well as the manufacturer of the highest quality chillers for medical applications. No other chiller manufacturer has been doing it longer.

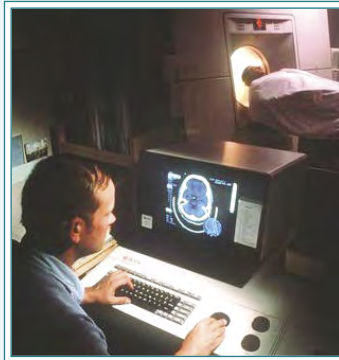

## What makes **FILTRINE** different?

Over 80 years ago *Filtrine* decided to use the storage method of cooling. This fly-wheel approach has stood the rigorous test of time and provides:

- **Consistent outlet temperatures** even with the wide and variable load swings typical in medical applications.
- **Low energy consumption** due to long cooling cycles (fewer stops and starts) and lower condensing temperature.
- **No risk** of chiller barrel freeze-up.
- **Reliability.** Typically, chiller operating lifetime is 2-3 decades.
- **Glycol-free solutions** that are more environmentally friendly without the risk of freeze up.
- **Demanding ambient conditions** from -30°F to 120°F.
- **Multiple medical systems or multi-modality cooling** from a single chiller with full redundancy and fail-safe backup (MRI/CT, MRI/MRI, CT/CT, LinAcc/LinAcc)

**These leading medical equipment manufacturers recommend *Filtrine* in their planning documents:**

- Varian Medical Systems
- Siemens Medical Solutions
- Hitachi Medical Systems
- GE Medical Systems
- Aurora Imaging Technology
- Philips Medical Systems
- Elekta

*See Medical Chiller Selection Chart (page 3) for specific model designs for each manufacturer.*

**As chiller experts in the medical field, we have learned what is vital to our users:**

- **Proper installation**
- **Trouble-free start up**
- **No-hassle 24/7 operation**
- **Quick response for service**

This translates to more scan time and productivity for the medical facility.

**FILTRINE** actively maintains a roster of over 250 service agents, nation-wide, so the call for service is answered quickly and effectively. Your problem is resolved by technicians experienced in servicing and repairing of equipment for medical applications.

Our field sales engineers are fully trained and well-versed in our chiller design options and are eager to meet with the engineer, architect, owner or project manager to address any chiller questions or concerns.

**MEDICAL CHILLER SPECIFICATIONS AND SELECTION CHART**

MFR	SYSTEM	MFR MODEL	HEAT DISSIPATED INTO WATER		COOLANT FLOW RATE		COOLANT TEMP.		FILTRINE CHILLER MODEL	FILTRINE ENGINEERING BULLETIN
			BTU	KW	GPM	LPM	°F	°C		
AURORA	MRI	1.5T	24,326	7	5.0	19	56	13	PCP-200-30-HTX	607-2AUR
ELEKTA	LIN. ACC.	SL SERIES, PRECISE OR SYNERGY	40,944	12	13.2	70	63	17	PCP-300G-44	608-3SL2
GE	MRI	OPTIMA MR450W	167,237	49	35	158	46.4	8	PCP-2000S-230	608-20-GE
	MRI	SIGNA 1.5T	28,320	8.3	2.5	9.5	60	16	PCP-200-33	607-2GE5
	MRI	SIGNA MR750 and DISCOVERY MR450	238,840	70	35	158	46.4	8	PCP-3000S-330	608-30-GE
	MRI	SIGNA HDx 3.0T	62,464	18.3	10.5	40	48	9	PCP-750S-98	608-7.5GE-HDx
HITACHI	MRI	ALTAIRE	41,785	11	2.5	9.5	56	13	PCP-500G-ARC-HTX	608-5HIT-ARC-HTX
	MRI	ECHELON	102,048	30	18	68	58	14	PCP-1000S-140-ARC-EXCU	608-10HIT-EXCU
PHILIPS	CT	BRILLANCE 16	38,300	11	7.0	27	50	10	PCP-500G-60	608-5PH-60
	CT	MX8000 QUAD	38,300	11	7.0	27	50	10	PCP-500G-60	608-5PH-60
	MRI	ACHIEVA DUAL 1.5T	136,498	40	28	106	54	12	PCP-1500S-180	608-15PH
	MRI	ACHIEVA DUAL 3T	136,498	40	28	106	54	12	PCP-1500S-180	608-15PH
	MRI	ACHIEVA NOVA 1.5T	136,498	40	28	106	54	12	PCP-1500S-180	608-15PH
	MRI	ACHIEVA PULSAR 1.5T	119,436	35	28	106	54	12	PCP-1000S-140	608-10PH1.5T
	MRI	ACHIEVA PULSAR HP	119,436	35	28	106	54	12	PCP-1000S-140	608-10PH1.5T
	MRI	ACHIEVA QUASAR 3T	136,498	40	28	106	54	12	PCP-1500S-180	608-15PH
	MRI	ACHIEVA 1.5T incl 781 Gradient Amplifier	119,436	35	28	106	54	12	PCP-1000S-140-ARC	608-10PH1.5T-ARC
	MRI	ACHIEVA 1.5T incl 781 Gradient Amplifier	119,436	35	28	106	54	12	PCP-1000S-140-WP	608-10PH1.5T-WP
	MRI	ACHIEVA 3.0T INGENIA 1.5T/3.0T incl 781 Gradient Amplifier	119,436	35	28	106	54	12	PCP-1000S-140-A-WP	608-10PH3.0T&1.5T-WP
	MRI	ACHIEVA 1.5T incl 781 Gradient Amplifier	136,498	40	28	106	54	12	PCP-1500S-180-ARC	608-15PH-ARC
	MRI	ACHIEVA 1.5T incl 781 Gradient Amplifier	136,498	40	28	106	54	12	PCP-1500S-180-A-WP	608-15PH-A-WP
	MRI	ACHIEVA 3.0T INGENIA 1.5T/3.0T incl 781 Gradient Amplifier	136,498	40	28	106	54	12	PCP-1500S-180-A-WP	608-15PH3.0T&1.5T-WP
	MRI	PANORAMA .6T	97,000	28	13.2	50	47	8	PCP-1000S-140	608-10PH.6T
	MRI	PANORAMA .23T	95,000	28	20.6	78	51	11	PCP-1000S-140	608-10PH.23T
	MRI	PANORAMA 1.0T	102,365	30	26	98	50	10	PCP-1000S-140	608-10PH1.0T

**CHART CONTINUED ON NEXT PAGE**

**MEDICAL CHILLER SPECIFICATIONS AND SELECTION CHART**

MFGR	SYSTEM	MFR MODEL	HEAT DISSIPATED INTO WATER		COOLANT FLOW RATE		COOLANT TEMP.		FILTRINE CHILLER MODEL	FILTRINE ENGINEERING BULLETIN
			BTU	KW	GPM	LPM	°F	°C		
<b>SIEMENS</b>	CT	SENSATION 16, 40 & 64	44,369	13	7.0	27	50	10	SMS-500G-70	608-5SMS-60
	CT	SOMATOM DEFINITION	51,182	15	7.0	27	50	10	SMS-500G-70	608-5SOM-70
	CT	SOMATOM DEFINITION AS	44,369	13	7.0	27	50	10	SMS-500G-70	608-5SOM-70
	CT	SOMATOM DEFINITION FLASH	58,045	17	7.0	27	50	10	SMS-750G-80	608-7.5SMS-80
	LIN. ACC.	ONCOR IMPRESSION PLUS	102,000	30	7.5	29	65	18	SOC-1000G-122	608-10IMP-122
	LIN. ACC.	ARTISTE	102,000	30	7.5	29	65	18	SOC-1000G-122	608-10SMS-ART
	MRI	MAGNETOM AVANTO	214,964	63	26	98	48	9	SMS-2500-270	608-25MR
	MRI	MAGNETOM ESPREE	163,783	48	26	98	48	9	SMS-2000-230	608-20SMS
	MRI	MAGNETOM ESSENZA	71,655	21	8.0	30	48	9	SMS-750S-98	608-7.5SMS-ESS
	MRI	MAGNETOM SYMPHONY	170,650	50	21	76	48	9	SMS-2000-230	608-20MR
	MRI	MAGNETOM TRIO	214,964	63	26	08	48	9	SMS-2500-270	608-25MR
	MRI	VERIO	214,964	63	26	08	48	9	SMS-2500-270	608-25MR
	CYCLOTRON	ECLIPSE	70,000	21	10.0	39	48	9	SMS-750S-98	608-7.5SMS-ECL
<b>VARIAN</b>	LIN. ACC.	CLINAC 600C & 6EX	23,000	7	4.0	15	68	20	PCP-200-24	607-2.75CL
	LIN. ACC.	CLINAC 21EX, 23EX, iX	85,350	25	8.0	30	68	20	PCP-750G-96	607-7.75CL
	LIN. ACC.	CLINAC TRILOGY	85,350	25	8.0	30	68	20	PCP-750G-96	607-7.75CL
	LIN. ACC.	CLINAC SILHOUETTE	85,350	25	8.0	30	68	20	PCP-750G-96	607-7.75CL
	LIN. ACC.	TRUEBEAM & TRUEBEAM STX	85,379	25	8.0	30	68		PCP-750G-96	608-7.75CL

**CHART CONTINUED FROM PREVIOUS PAGE**

# Chiller specs, start-up and warranty

## GENERAL SPECIFICATIONS AND CONSTRUCTION FEATURES SHARED BY ALL FILTRINE MEDICAL CHILLERS

### Cooling Tank

Tank constructed of welded stainless steel plate — tested at 250 psi for 125 psi working pressure. Cooling tank insulated with closed cell thermo-elastomer with R factor of 3.7 and supplied with air vent and drain connections.

### Evaporator

Immersion coil design, constructed of heavy stainless steel tubing, mounted in a welded stainless steel storage tank.

### Condensing Unit

Oversized, lifetime lubricated compressor mounted on vibration isolators. Extra large copper condenser with aluminum fins and heavy duty fan motors, all designed to operate in ambients to 90°F. Complete ready-to-use system is fully charged with HFC refrigerant and capacity tested.

### Circulation Pump

Pump mounted on a rubber pad over a stainless steel condensation tray and supplied with unions and service valves and a pressure relief bypass valve. All piping and fittings brass, copper or bronze and insulated with R factor 3.7 closed cell thermo-elastomer.

### Controls

Reliable analog thermostat control for easy maintenance. Refrigeration controls include high/low pressure control, freeze control, thermostatic expansion valve, dehydrator, moisture indicator and magnetic starter.

### Adjustable Differential Thermostat

40° to 90°F (4° to 32°C) Temperature stability  $\pm 1.5^\circ\text{F}$  (0.8°C)

### Cabinet

All components are mounted in a rugged, rust proofed and enameled aluminum cabinet on a welded angle iron frame with channel skids for easy mounting. Top and corner legs are stainless steel. Panels are easily removed for complete access to all components.

FILTRINE IS ISO 9001:2015 CERTIFIED

PRODUCT LINE  APPROVED  MARK AVAILABLE

### **START-UP and FIRST YEAR SERVICE**

FILTRINE Mfg. Co. provides start-up and first year service on all parts and labor. Regular maintenance on a yearly contract basis is a wise investment and will prevent costly downtime.

### **WARRANTY**

All parts are covered FOB jobsite for (12) months from the start date or (15) months from date of shipment or whichever comes first.

### **SERVICE MAKES THE DIFFERENCE**

Recognizing that downtime on critical medical equipment is unacceptable, Filtrine has established a national network of qualified service technicians, selected because of their extensive experience working on medical equipment chillers and their location within the "Emergency Response Zone" (approximately 40 miles). This expert and quick service is available on an 8/5 or 24/7 basis for all Filtrine medical chillers and heat exchangers.

# Chiller configurations for every installation

**Filtrine** recognizes the importance of keeping valuable floor space available for medical imaging equipment. To accommodate this need, Filtrine chillers are available in six configurations which are suitable for almost any application. We can custom engineer special sizes and configurations based on your specifications.

## SELF-CONTAINED / AIR COOLED CONDENSER INDOOR INSTALLATION

All components - compressors, condensers, etc. are contained within a single housing, located within the building where it will be used. **(Suffix -A)**

## SELF-CONTAINED / WATER COOLED CONDENSER INDOOR INSTALLATION

Water cooled condenser for hookup to city water or tower water. All components - compressors, condensers, etc. are contained within a single housing, located within the building where it will be used. **(Suffix -W)**

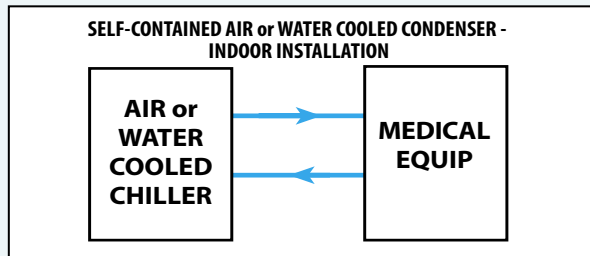

## REMOTE / AIR COOLED CONDENSER SPLIT CONFIGURATION

Supplied with a separate weather-resistant air cooled condenser mounted outdoors at a remote location - usually within 100 feet of the chiller. The standard remote condenser may be used in a range of ambient temperatures from -20 to 100°F. High Ambient (HA) options are available. By installing the condenser outdoors, noise and exhaust heat are greatly reduced or eliminated within the building where the chiller is in use. Due to the extra demand placed upon the condenser by outdoor temperature, the remote air condenser is sized according to the temperature in which it will be expected to operate. Consult the factory for selection of the remote condenser for your chiller. **(Suffix -AR)**

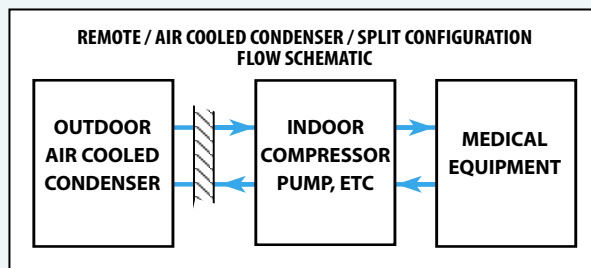

## REMOTE / AIR COOLED CONDENSING UNIT

Outdoor refrigeration system, indoor evaporator and pump only - saves indoor space and reduces noise and exhaust heat and *no glycol is used*. **(Suffix -ARC)**

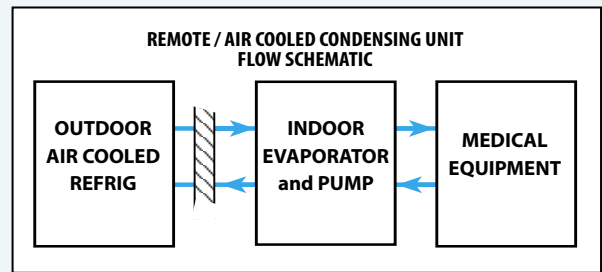

## WEATHER-RESISTANT / OUTDOOR INSTALLATION

Weather-resistant models have the same specifications and profile as our standard self-contained units, but are designed for rooftop installation and operation. Weather-resistant models come with anodized aluminum panels and stainless steel corner legs and top. **(Suffix -A-WP)**

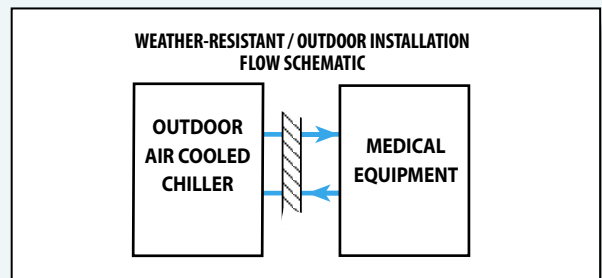

## WEATHER-RESISTANT / LOW PROFILE OUTDOOR INSTALLATION

Unique to Filtrine are weather-resistant, low profile models which incorporate all the specifications and features of the standard weather-resistant models, but are housed in a low profile cabinet which will not detract from the visual appearance of the roof line. **(Suffix -A-WP-LP)**

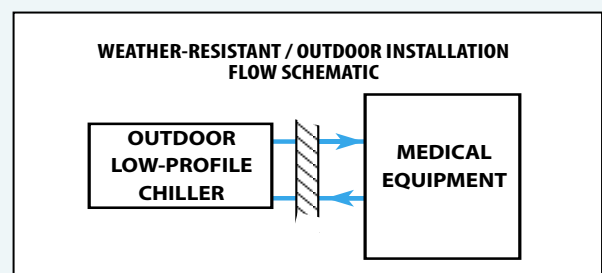

# Quick Connect Panel...interface and monitor for medical equipment

## FILTRINE QUICK CONNECT PANELS... DESIGNED ESPECIALLY FOR MEDICAL EQUIPMENT

A properly operating chiller is essential for the operation of your medical equipment such as MRI, CT or linear accelerators. This panel provides diagnostic information on the chiller so that you can see at glance if it is operating correctly and carry out maintenance, if required, to prevent down-time. Filtrine has designed these wall-mounted panels in consultation with medical equipment manufacturers to make sure every installation includes this vital information.



TYPICAL QCP

## EASY HOOK UP CONNECTIONS AND MONITORING

Install this compact panel between chiller and equipment for instantaneous availability of autoswitchover to city water or plant chilled water, pressure gauges, temperature gauges, flow meter and in-line filter. Panel is complete with all valves, solenoids, bypass and drains installed. Easy-to-open door on front of panel provides access to valves and filter for routine maintenance. Complete unit housed in aluminum cabinet with stainless steel top, bottom and frame.

## TEMPERATURE GAUGES

For water entering and leaving equipment are dial-type, in Celsius and Fahrenheit, on the water supply and return.

## PRESSURE GAUGES

Dial-type, in psi and bar on the water supply and return.

## FLOW METER

Analog type with moving indicator in liters and gallons per minute, on the water supply and return.

## FILTER

Bag-type, using 50 micron bag with less than 1 psi pressure drop when new. Filter located inside the panel; includes bypass piping to ensure easy filter element change.

## QCP-ASX... GLYCOL LOSS SOLVED

### COMPLETE EQUIPMENT CONNECTIONS & PROTECTION:

Compact, wall mountable unit which provides foolproof hookups for coolant connections between medical equipment, the chiller unit and backup cooling as required.

**NO MORE GLYCOL DOWN THE DRAIN:** Inter-connection with city water when switchover occurs eliminated. Sealed glycol circuit insures clean, safe cooling.

**NO SHUTDOWN FROM POWER FAILURE:** Backup pump connected to emergency power insures continuous operation.

**NO MORE FOULING OF COOLANT:** Two independent cooling circuits... no cross-contamination.

**HEAT EXCHANGER:** Separate circuits operated by solenoid valves to allow equipment cooling by chiller or city water.

**BACKUP COOLANT PUMP:** Backup pump is wired to emergency lighting circuit. In event of power loss, pump provides required flow and pressure to the medical equipment coolant loop.

## QCP-ASX... FLOW SCHEMATIC

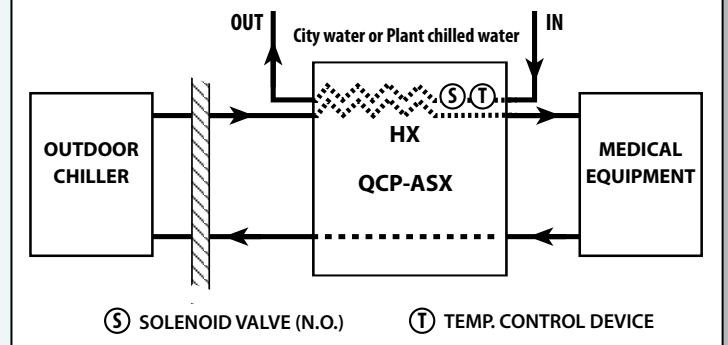

## QCP-AS... AUTOMATIC SWITCHOVER

Water inlet with backflow preventer and drain to be included for connection to city water supply for emergency use. Solenoids to be included to automatically switchover to city water cooling utilizing trip-points on temp, flow and/or power loss.

## QCP-AS... FLOW SCHEMATIC

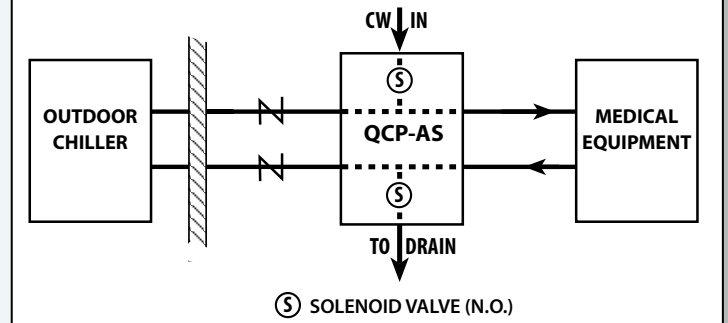

## STANDARD QCP FLOW SCHEMATIC

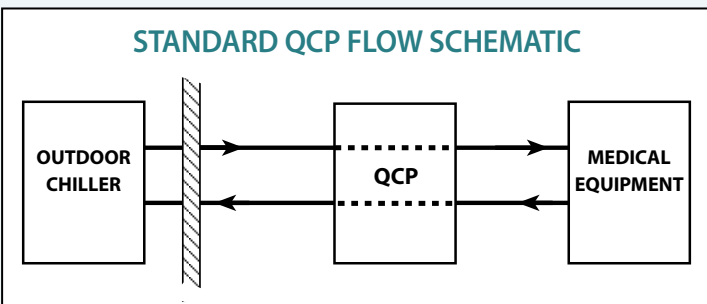

# Chiller options and accessories to meet every requirement

## CABINETRY

### Custom Dimensions

Built to fit into unusual locations. Two-piece construction also available.

### Corrosion Resistance

Epoxy coated condenser or special cooling fin material for salty or chemical environments.

### Low Profile

Less than four feet tall to reduce visibility on rooftop installation.

### Vibration Pads

Neoprene pads in rugged, cast-iron casings mounted under channel skids.

### Stainless Steel Cabinet

Cabinet and frame constructed throughout of stainless steel.

### Space Saver Design

Increases usable floor space by using smaller footprint cabinet.

### Rubber Casters

For complete mobility.

### Weather Resistant

Outdoor installation in most climates.

## COMPONENTS

### Blower

Built into cabinet, to duct hot air out of building.

### Deionizer

Installed in-line (specify requirements).

### Dual Pumps

Provide complete backup. Available with automatic switchover in case of failure.

### Glycol Safe

For installations where the entire chiller cannot be indoors, ARC design (see p. 5) eliminates the need for glycol. The QCP-ASX design (see p. 6) prevents glycol from going down the drain.

### High Ambient

Designed for up to 110° or 120°F.

### In-Line Filter

Removes sediment from makeup ensuring clean liquids.

### In-Line Heater

Heat liquids to optimum temperature automatically. Specify heater kw and temperature range.

### Pure System

For deionized water or other liquids that cannot come in contact with copper or brass. Evaporator fabricated out of type 304 stainless steel with polypropylene piping and fittings. Type 316 stainless steel also available for salt water or acids.

### Redundancy

For critical applications where downtime can be extremely expensive. Fail-safe design with 50% or 100% backup refrigeration and circulating system packaged in a single housing.

### Remote Air Cooled Condenser

Ready for remote installation on roof.

### Water Cooled Condenser

For hookup to city or tower water or plant chilled water.

## CONTROLS

### Auto Fill

Float switch senses liquid level in tank, activates solenoid valve on makeup line to keep tank full.

### Auto Switchover to City or Plant Chilled Water

Auto switchover to city or plant chilled water in case of pump or compressor failure (see p. 6).

### Close Temperature Control

Solid state temperature controller and hot gas bypass maintain liquid temperature at  $\pm 0.5^\circ\text{F}$  of setting.

### Dial Thermometer

For makeup and/or discharge temp.

### Flow Meter

Mounted on discharge line.

### Fused Disconnect Switch

On power supply.

### High/Low Temperature Interlock

In-line sensor activates warning light, audible alarm or shuts down machine to prevent damage if water temperature exceeds high temperature limit (indicating possible refrigeration failure) or gets too cold.

### Low Ambient

For down to  $-30^\circ\text{F}$ .

### Low Flow Interlock

In-line sensor activates warning light, audible alarm or shuts down machine to prevent damage if water flow rate falls below low flow limit (indicating possible pump failure).

### Low Pressure Interlock

In-line sensor activates warning light, audible alarm or shuts down machine to prevent damage if water pressure falls below low flow limit (indicating possible pump failure).

### Low Temperature

Chill water down to  $34^\circ\text{F}$  or antifreeze liquids down to  $0^\circ\text{F}$ . Consult Filtrine for capacities.

### Low Water Level Interlock

In-line sensor activates warning light, audible alarm or shuts down machine signifying low water level in tank.

### Pressure Gauge

For makeup and/or discharge pressure.

### Remote Panel

For alarm indication and start/stop switch.

### Solid State Controls/Digital Indicator

For temperature, pressure, flow, remote control panel, recorders, etc.