



B103-107-16-MOD

Recessed Water Bottle Filling Station with Non-Recessed Vandal Proof Drinking Fountain



Water bottle filling station*, fountain support arm, access panel, "Soft Touch" button valve*, and bubbler* shown in standard stainless steel satin finish

PRODUCT COMPLIANCE*

ADA Compliance
Buy America Act
CA Proposition 65
Components: CA NSF/ANSI 372 (Lead Free)
**More available on request*

**"Hands Free" option available

Options and finishes may differ from image shown.

Dimensions in drawing subject to options selected.

Features

- 16" diameter, 16 ga. fountain Bowl
- No plastic parts
- 100% made in the USA
- Manufactured with lead-free materials
- Integral drain in bowl for ease of cleaning
- 1/4" steel support arm and wall bracket capable of supporting 500 lbs.
- Long-lasting, durable stainless steel water dispenser, promotes refilling of water bottles
- 16 ga. plate secured with tamper-resistant screws for added security
- Standard 6" access panel
- Options include sensor activation, bottle fillers, bottle counters, finishes, bubbler valves, and more...

Recommended Add-ons

Chiller

Equip your fountain with a Filtrine point-of-use or remote chiller to cool your drinking water. We can help you select the most economic chiller model to fit your demand.

Purifier

Ensure that your drinking water is of the highest quality by adding a Filtrine Taste Master® purifier cabinet underneath the fountain or a remote purification system serving all fountains in the building.

Top View

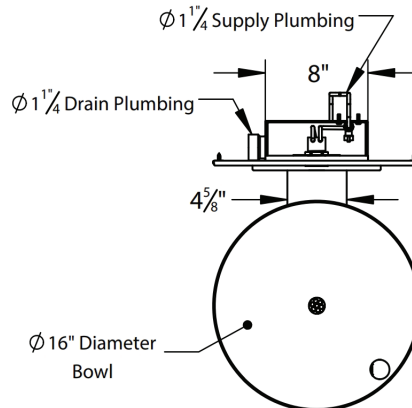

Front View

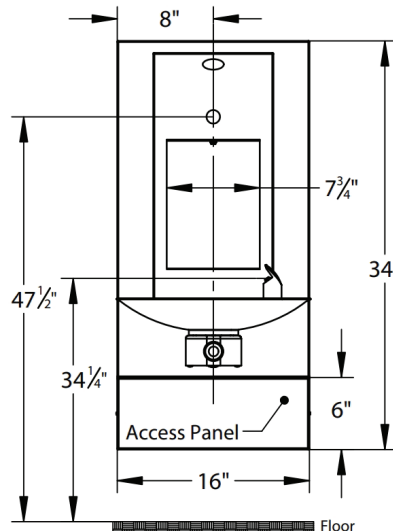

Side View

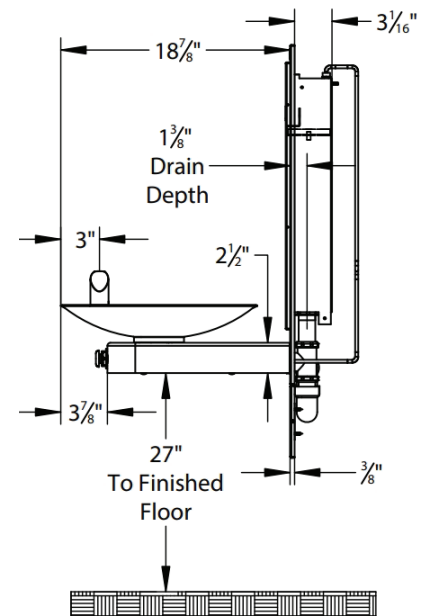

For options, finishes and more see page 2





Filtrine Drinking Water Non-Recessed Fountain Options

[S] - Standard
♿ - ADA Compliant

Standard Security Panel and Vandal Proof Bubbler [S]



"Soft Touch" Button and Projector Bubbler with Recessed Set Screws



16 ga. Plate Secured with Tamper-Resistant Screws for Added Security

Standard Bubbler Controls

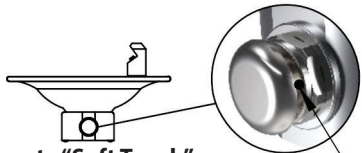

Remote "Soft Touch" Button Valve [S]

Tamper-Resistant Screws in Bubbler and "Soft Touch" Button (if applicable)

Bottle Filling Station Controls

Flush Mounted "Soft Touch" Push Button [S]



Optional "Hands Free" Sensor Activated Valve



• Features automatic shutoff with [20] second delay
"Hands Free" Sensor Activator

- Optional Bottle Counter
- Optional Bottle Decal
- Optional Downlight

Power Supply Options:
(Choose only one)

- Connect 12v Transformer to A/C Power Supply [S] or
- Use 12v Wall Plug

120/60/1 Voltage Required

Optional Bottle Counter

Note: Only available with Hands Free units



• Digital display of approximate number of bottles saved through filler usage

Optional "Hands Free" Fountain Sensor Activated Bubbler

Include "Hands Free" Bubbler

- Features automatic shutoff with [20] second delay
- Helps prevent vandalism and water waste

*120/60/1 voltage required

"Hands Free" Sensor Activator



Other options are available, please contact the factory for more choices.

Access Panel: 6" Access Panel [S] No Access Panel Custom Access Panel: _____"

Vandal Proof Option: Yes [S] No

Bubbler Options:



F-507

All finish options available



F-501



F-501-L



F-502

Available in:
Stainless Steel,
Oil-Rubbed Bronze,
or Any Powder Coat
Options

Fountain Finish (Check One)

- Satin Stainless [S] Satin Bronze Statuary Bronze Oil-Rubbed Bronze Oil-Rubbed Bronze Powder Coat Powder Coat _____

Optional Cover Plate Finish (Check One)

- Satin Stainless [S] Satin Bronze Statuary Bronze Oil-Rubbed Bronze Oil-Rubbed Bronze Powder Coat Powder Coat _____



Satin Stainless Steel [S]



Satin Bronze

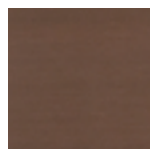

Statuary Bronze

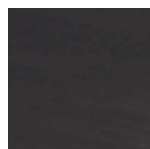

Oil Rubbed Bronze

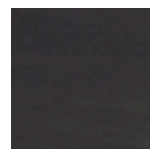

Oil Rubbed Bronze Powder Coat
(Applied to Stainless Steel)



Powder Coat



Mounting Plate Details (Front)

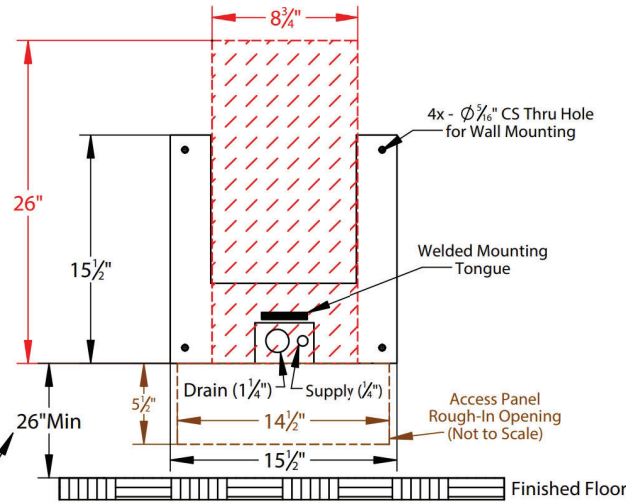

Mounting Plate Rough-In Dimensions (hatched, left)

MODEL	HEIGHT	WIDTH	DEPTH
B103-107-MOD	26"	8 3/4"	4"

Access Panel Rough-In Dimensions (hatched, left)

MODEL	HEIGHT	WIDTH
Standard Panel	5 1/2"	14 1/2"

All views shown are for typical installation of B103-107-16-MOD.

Views, dimensions and diagrams may change for specific installation requirements

26" Minimum From Bottom of Mounting Plate to Finish Floor Equals 34 1/4" to Lower Bubblers Spout

Typical Assembly Instructions (Always Install Per Local Code)

1. Cut rough opening for fountain, bottle filler and access panel as shown above and install blocking or fixture carrier as required to support the assembly.
2. Run drain pipe to slip coupling unions (shown below) and install drain trap per local code.
3. Run supply lines with service valve, if necessary (shown below).
4. Fasten mounting plate over rough opening with 5/16" countersunk lag bolts with bottom of plate 26" above the floor to meet ADA fountain height requirements.
5. Install cover plate over the mounting plate.
6. Place B103 Frame Assembly in cover plate opening and mount to in wall bracing using holes located on the side of the B103 frame.
7. Install B103 Cover Plate over the B103 Frame Assembly and secure in place using provided set screws.
8. Slide the 107 fountain over the horizontal tongue protruding from the mounting plate and fasten arm with set screws pushing slightly against the cover plate or finished wall.
9. Connect drain lines to slip coupling and connect supply water connections.
10. To install the Access Panel, measure, mark and install the access panel "L" brackets with #8-32 screws and align access panel to cover plate with alignment pins.

Exploded On-Wall Installation View B103-107-16-MOD

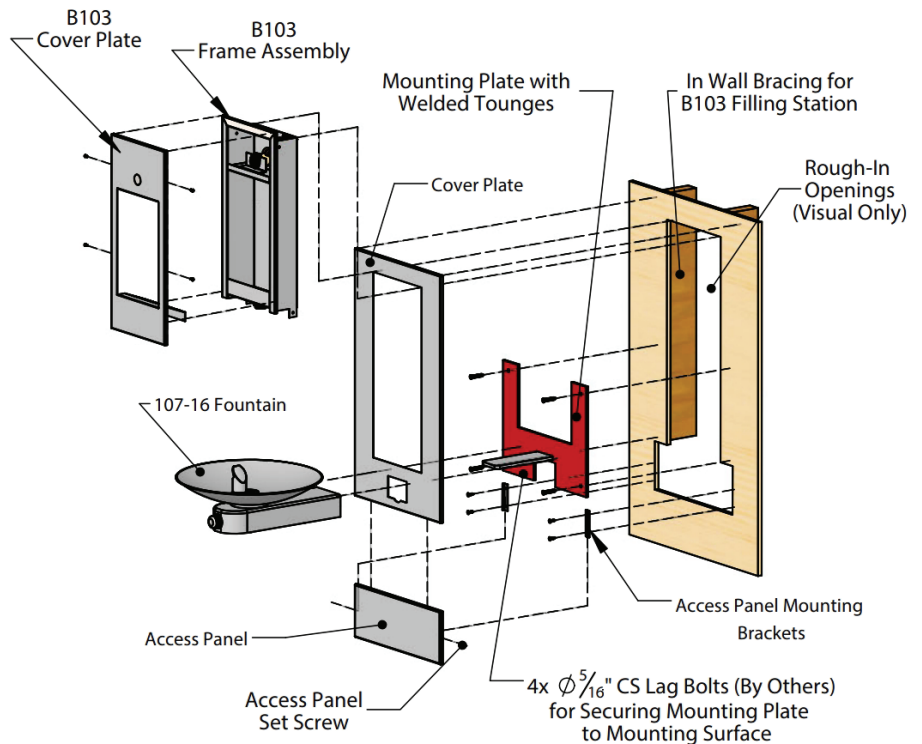

Access Panel Mounting Brackets Installation Details

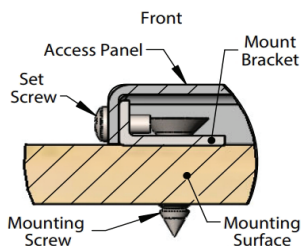

Typical Drain Plumbing Detail (In-Wall Plumbing Provided by Others, Install Per Local Code)

Back View (Cropped)

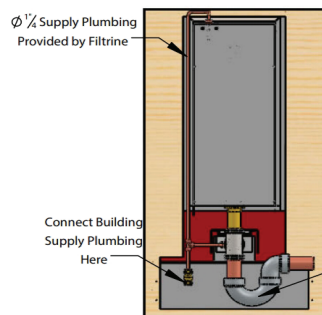

Top View (Cropped)

