



107-16-HL-LS

Non-Recessed Vandal Proof High/Low Drinking Fountain with Cane Apron



Fountain support arm, optional bottle filler, access panel, "Soft Touch" button valve*, and bubbler* shown in standard stainless steel satin finish

PRODUCT COMPLIANCE*

ADA Compliance
Buy America Act
CA Proposition 65
Components: CA NSF/ANSI 372 (Lead Free)
**More available on request*

*Hands Free" option available

Options and finishes may differ from image shown.

Dimensions in drawing subject to options selected.

Features

- [2] 16" diameter, 16 ga. fountain Bowls
- No plastic parts
- 100% made in the USA
- Manufactured with lead-free materials
- Integral drain in bowl for ease of cleaning
- 1/4" steel support arm and wall bracket capable of supporting 500 lbs.
- Cover plate and access panel to match bowl finish or choose from unlimited powder coat colors
- 16 ga. plate secured with tamper-resistant screws for added security
- Standard 6" access panel
- Options include sensor activation, bottle fillers, bottle counters, finishes, bubbler valves, and more...

Top View

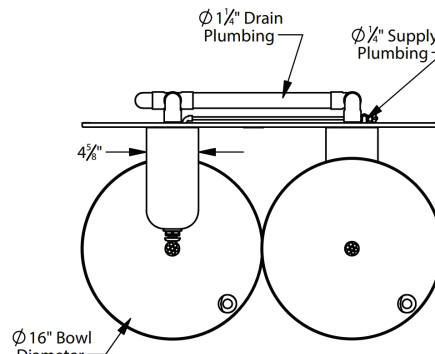

Select Low Fountain Location

- Left [S] Right

Side View

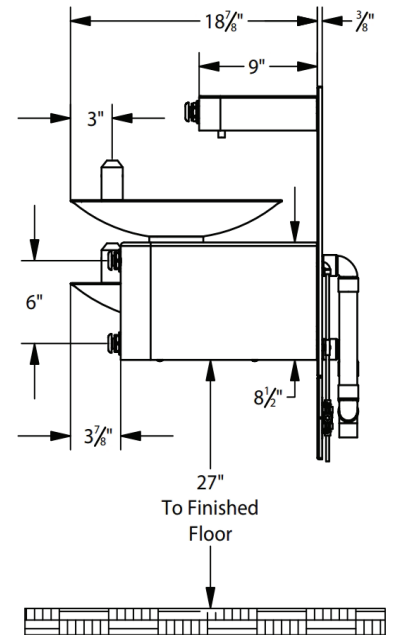

Front View

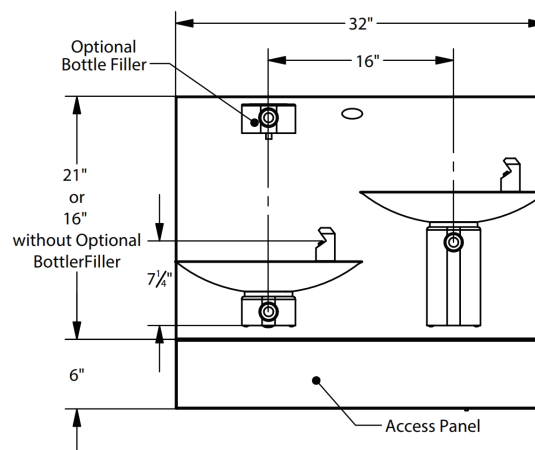

Recommended Add-ons

Chiller

Equip your fountain with a Filtrine point-of-use or remote chiller to cool your drinking water. We can help you select the most economic chiller model to fit your demand.

Purifier

Ensure that your drinking water is of the highest quality by adding a Filtrine Taste Master® purifier cabinet underneath the fountain or a remote purification system serving all fountains in the building.

For options, finishes and more see page 2





Filtrine Drinking Water Non-Recessed Fountain Options

[S] - Standard

- ADA Compliant

Standard Security Panel and Vandal Proof Bubbler [S]



"Soft Touch" Button and Projector Bubbler with Recessed Set Screws



16 ga. Plate Secured with Tamper-Resistant Screws for Added Security

Standard Bubbler Controls

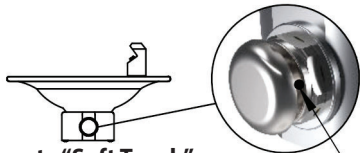

Remote "Soft Touch" Button Valve [S]

Tamper-Resistant Screws in Bubbler and "Soft Touch" Button(if applicable)

"Hands Free" Options



Bottle Counter*
• Digital display of approximate number of bottles saved through filler usage
*Only available with "Hands Free" units

Bottle Rest

• Located above fountain for reduced splash and one handed operation



"Hands Free" Sensor Activated Bottle Filler

- Features automatic shutoff (20 sec)
- Helps prevent vandalism and water waste

Power Supply Options:
(Choose only one)

- Connect 12v Transformer to A/C Power Supply [S] or
 - Use 12v Wall Plug
- 120/60/1 Voltage Required

"Hands Free" Sensor Activated Bubbler

Optional Bottle Fillers (Choose only one optional filler)

- Mounted 10½" above fountain bowl
- Requires larger cover plate
- Comes standard with tamper proof screws
- Supply plumbing for filler provided by Filtrine

"Soft Touch" Button Vandal Proof Filler*



*Hands Free options available

"Soft Touch" Button F-520 Bottle Filler*



*Hands Free options available

Other options are available, please contact the factory for more choices.

Access Panel: 6" Access Panel [S] No Access Panel Custom Access Panel: _____"

Vandal Proof Option: Yes [S] No

Bubbler Options:



F-507

All finish options available



F-501



F-501-L



F-502

Available in:
Stainless Steel,
Oil-Rubbed Bronze,
or Any Powder Coat
Options

Fountain Finish (Check One)

- Satin Stainless [S] Satin Bronze Statuary Bronze Oil-Rubbed Bronze Oil-Rubbed Bronze Powder Coat Powder Coat _____

Optional Cover Plate Finish (Check One)

- Satin Stainless [S] Satin Bronze Statuary Bronze Oil-Rubbed Bronze Oil-Rubbed Bronze Powder Coat Powder Coat _____



Satin Stainless Steel [S]

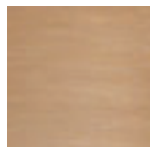

Satin Bronze

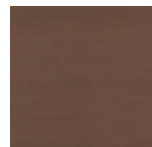

Statuary Bronze

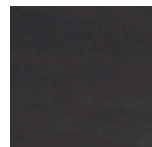

Oil Rubbed Bronze

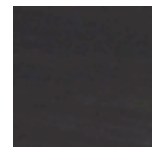

Oil Rubbed Bronze Powder Coat
(Applied to Stainless Steel)



Powder Coat

Filtrine Mfg. Co. • 15 Kit St. Keene, NH 03431 USA
800-930-3367 • 603-352-5500 • FAX 603-352-0330
www.filtrine.com • drinking_water@filtrine.com



FILTRINE IS ISO 9001:2015 CERTIFIED BY NSAI
PRODUCT LINE APPROVED MARK AVAILABLE



107-16-HL-LS [EB]

REVISED
09.25.25

Mounting Plate Details (Front)

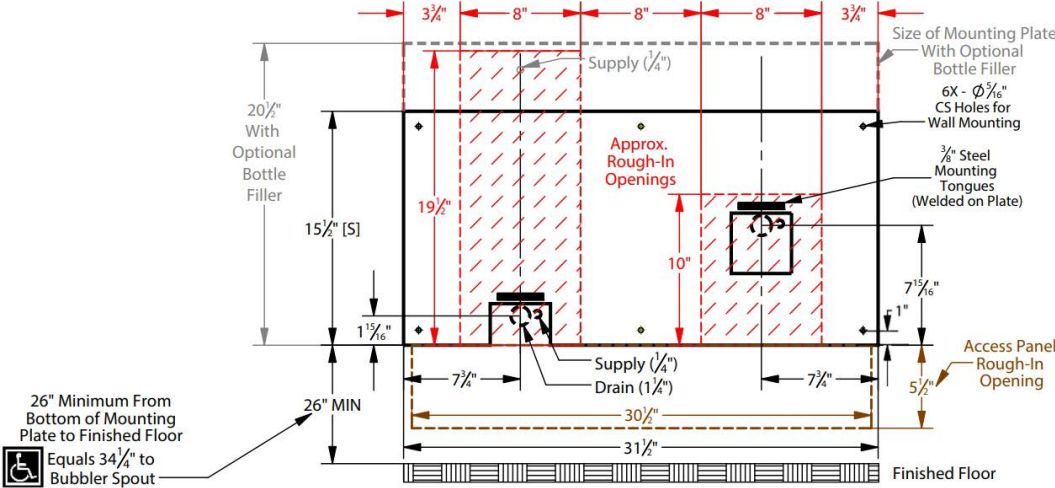

Mounting Plate Rough-In Dimensions (hatched, left)

MODEL	HEIGHT	WIDTH
107 Fountain	10"	8"
107 Fountain with Bottle Filler	19 1/2"*	8"

*If unit does not have an optional bottle filler, make all rough-ins equal.

Access Panel Rough-In Dimensions (hatched, left)

MODEL	HEIGHT	WIDTH
Standard Panel	5 1/2"	30 1/2"

All views shown are for typical installation of 107-16-HL-LS.

Views, dimensions and diagrams may change for specific installation requirements

Exploded On-Wall Installation View: 107-16-HL-LS

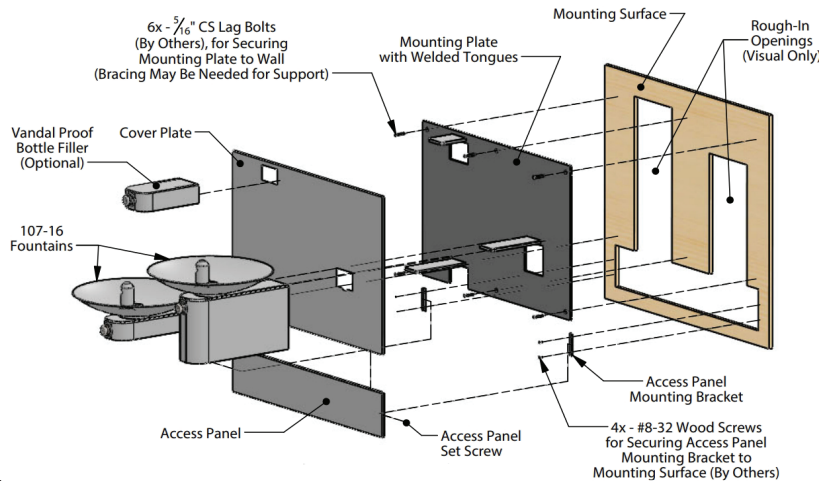

On-Wall Mounting Detail With Cover Plate

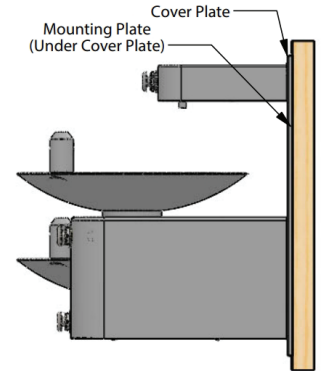

Behind-Wall Mounting Detail Without Cover Plate

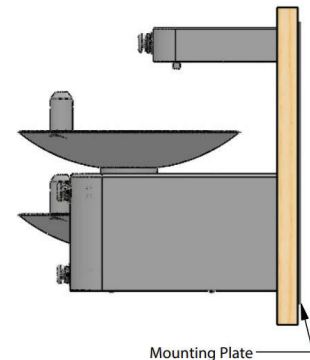

Typical Assembly Instructions (Always Install Per Local Code)

- Cut rough opening for fountain, bottle filler, and access panel as shown above and install blocking or fixture carrier as required to support the assembly.
- Run drain pipe to slip coupling unions (shown below) and install drain trap in wall per local code.
- Run supply water with service valve, if necessary (shown below).
- If optional bottle filler is included with order, attach piping assembly provided by Filtrine to the back side of the mounting plate with two screws and rubber gasket for standard bottle filler and flare connection for vandal proof bottle filler.
- Fasten mounting plate over rough opening with 5/16" countersunk lag bolts with bottom of plate 26" above the floor to meet ADA fountain height requirement.
- Install cover plate over the mounting plate for on-wall installations.
- Slide each fountain and vandal proof bottle filler arm (if ordered) over the horizontal tongues protruding from the mounting plate and fasten arms with set screws pushing slightly against the cover plate or finished wall.
- Connect drain line to slip coupling and connect water connection.
- If your model includes the access panel, measure, mark and install the included "L" brackets with #8-32 screws and align panel to cover plate with alignment pins.

Access Panel Mounting Brackets Installation Details

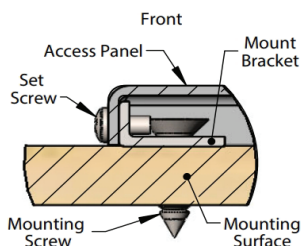

Typical Drain Plumbing Detail (In-Wall Plumbing Provided by Others, Install Per Local Code)

