



107-16-HHL-VP-TM

Non-Recessed, Vandal Proof Tri-Bowl Drinking Fountain
with Taste Master® Purifier



Fountain bowl, cover plate and purifier cabinet shown in standard stainless steel satin finish with "Soft Touch" button valves and bubblers and vandal proof bottle filler in mirror finish

Dimensions in drawing subject to options selected.

Features

- [3] 16" diameter, 16 ga. fountain bowls
- No plastic parts
- 100% made in the USA
- Manufactured with lead-free materials
- Integral drain in bowl for ease of cleaning
- 1/4" steel support arm and wall bracket capable of supporting 500 lbs.
- Matching cover plate and cabinet finishes including unlimited powder coat colors
- Options include vandal proof bubblers, bottle fillers, bottle counters, finishes, bubbler valves, and more...

Top View

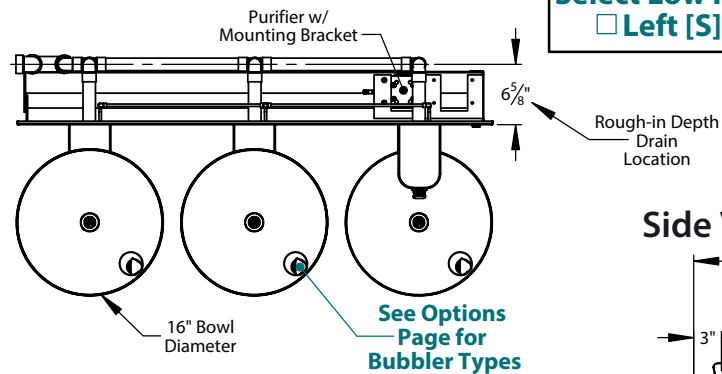

Select Low Fountain Location
 Left [S] Right

Side View

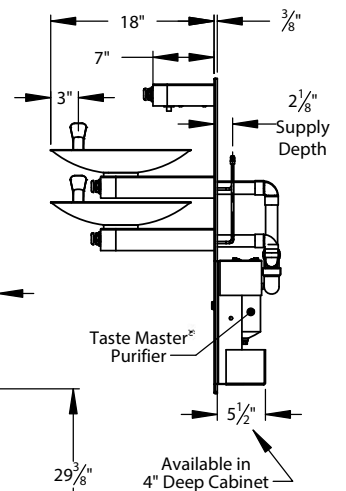

Front View

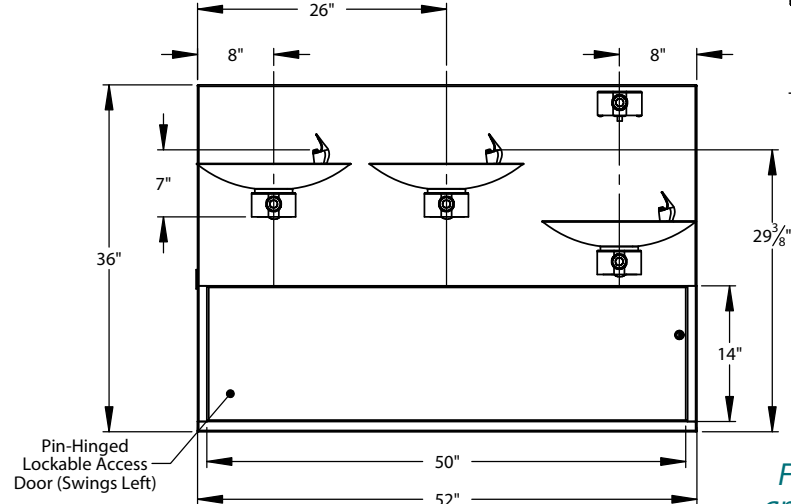

For options, finishes and more see page 2

107-16-HHL-TM Models Include:

Purifier: Taste Master® TMS1-0.5

- **Construction:** Stainless steel housing
- **Element:** Carbon block removes particulates, cysts, chlorine, organic odors and tastes. Exclusive seal design negates bypassing and leaking.

Recommended Add-ons

Chiller

Equip your fountain with a Filtrine point-of-use or remote chiller to cool your drinking water. We can help you select the most economical chiller model to fit your demand.





Filtrine Drinking Water Non-Recessed Fountain Options

[S] - Standard

- ADA Compliant

Standard Security Panel and Vandal Proof Bubbler [S]



"Soft Touch" Button and Projector Bubbler with Recessed Set Screws

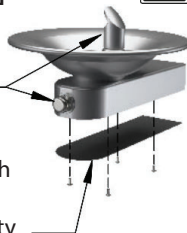

16 ga. Plate Secured with Tamper-Resistant Screws for Added Security

Standard Bubbler Controls

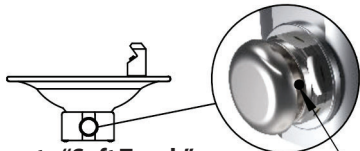

Remote "Soft Touch" Button Valve [S]

Tamper-Resistant Screws in Bubbler and "Soft Touch" Button(if applicable)

"Hands Free" Options



Bottle Counter*

• Digital display of approximate number of bottles saved through filler usage

*Only available with "Hands Free" units

Bottle Rest

• Located above fountain for reduced splash and one handed operation



"Hands Free" Sensor Activated Bottle Filler

- Features automatic shutoff (20 sec)
- Helps prevent vandalism and water waste

Power Supply Options: (Choose only one)

Connect 12v Transformer to A/C Power Supply [S] or

Use 12v Wall Plug

120/60/1 Voltage Required

"Hands Free" Sensor Activated Bubbler

Optional Bottle Fillers (Choose only one optional filler)

- Mounted 10½" above fountain bowl
- Requires larger cover plate
- Comes standard with tamper proof screws
- Supply plumbing for filler provided by Filtrine

"Soft Touch" Button Vandal Proof Filler*



*Hands Free options available

"Soft Touch" Button F-520 Bottle Filler*



*Hands Free options available

Other options are available, please contact the factory for more choices.

Access Panel: 6" Access Panel [S] No Access Panel Custom Access Panel: _____"

Vandal Proof Option: Yes [S] No

Bubbler Options:



F-507

All finish options available



F-501



F-501-L



F-502

Available in:
Stainless Steel,
Oil-Rubbed Bronze,
or Any Powder Coat
Options

Fountain Finish (Check One)

Satin Stainless [S] Satin Bronze Statuary Bronze Oil-Rubbed Bronze Oil-Rubbed Bronze Powder Coat Powder Coat _____

Optional Cover Plate Finish (Check One)

Satin Stainless [S] Satin Bronze Statuary Bronze Oil-Rubbed Bronze Oil-Rubbed Bronze Powder Coat Powder Coat _____



Satin Stainless Steel [S]

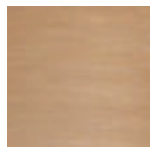

Satin Bronze

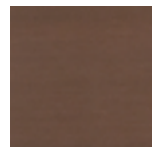

Statuary Bronze

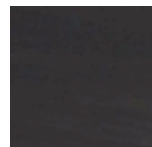

Oil Rubbed Bronze

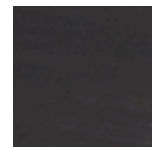

Oil Rubbed Bronze Powder Coat
(Applied to Stainless Steel)



Powder Coat

Filtrine Mfg. Co. • 15 Kit St. Keene, NH 03431 USA
800-930-3367 • 603-352-5500 • FAX 603-352-0330
www.filtrine.com • drinking_water@filtrine.com



FILTRINE IS ISO 9001:2015 CERTIFIED BY NSAI
PRODUCT LINE APPROVED MARK AVAILABLE



107-16-HHL-VP-TM [EB]

REVISED
01/17/2020

Mounting Plate Details (Front)

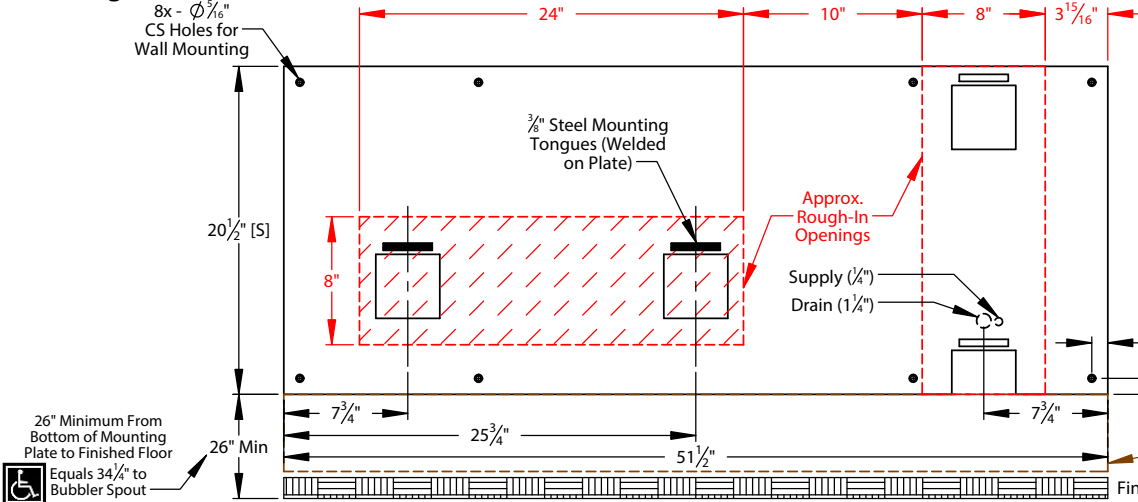

Approximate Rough-In Dimensions (hatched, left)

Model	Height	Width
Standard Plate	15 1/2"	8"
Bottle Filler Plate	20 1/2"	8"

Approximate Purifier Cabinet Rough-In Dimensions (outlined, left)

Model	Height	Width
Standard Cabinet*	16"	50 1/2"

*If height specified, rough-in height will be 1/2" less than specified height

1" TYP
Chiller Cabinet Rough-In Opening (Not to Scale)

All views shown are for typical installation of 107-16 HHL-VP-TM. Views, dimensions and diagrams may change for specific installation requirements

107-16-HHL-VP-TM Exploded and Dimensions Installation Views

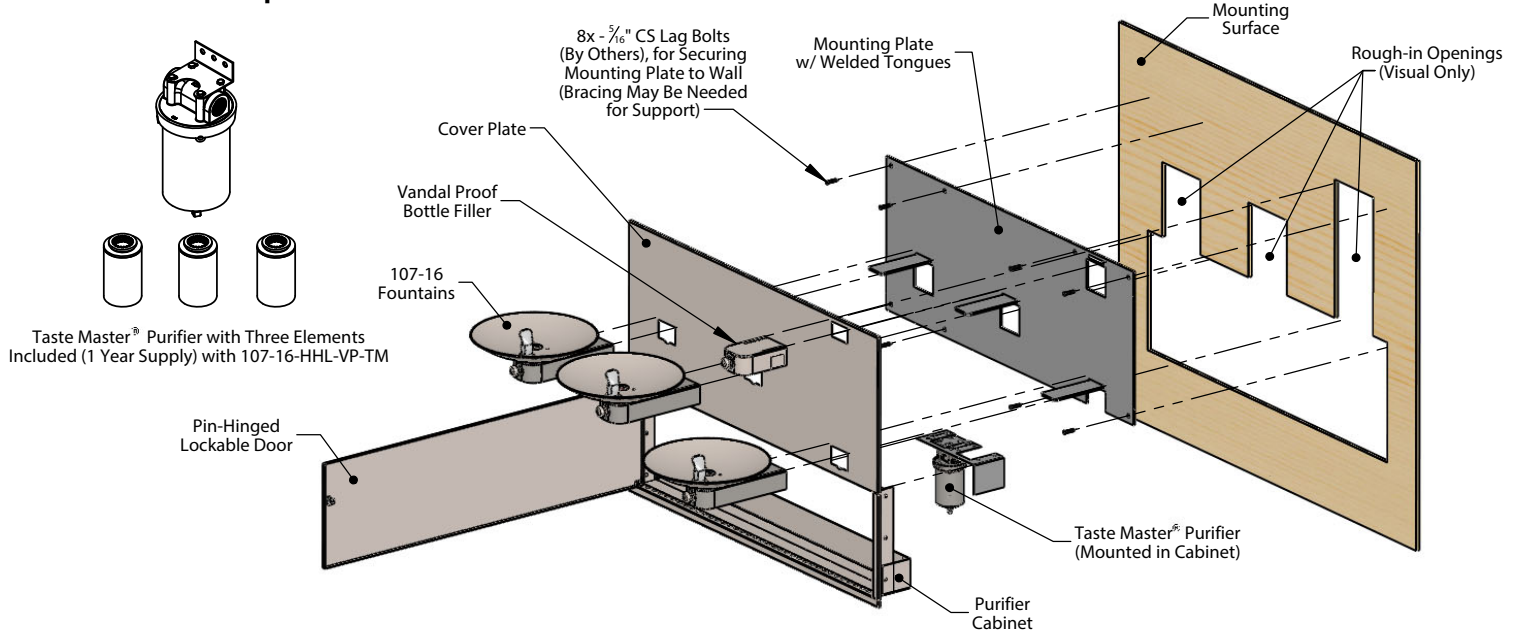

Typical Assembly Instructions (Always Install Per Local Code)

- Cut fountain rough openings per install requirements (rough opening example shown above) and install blocking or fixture carriers as required to support the drinking fountain mounting plate and purifier cabinet in a minimum 10" deep wall.
- Cut a separate rough opening extending below the fountain mounting plate, 16" high x 50 1/2" wide maximum rough in opening dimensions.
- Run drain piping to center of openings on mounting plate (dimensioned above), and install drain trap(s) in wall per local code.
- Run supply water line to mounted Taste Master® filter housing.
- If optional bottle filler is included with order, attach piping assembly provided by Filtrine to the back side of the mounting plate with two screws and rubber gasket for standard bottle filler and flare connection for vandal proof bottle filler.
- Fasten mounting plate to mounting surface over rough opening with 5/16" countersunk lag bolts with bottom of plate 26" above the floor to meet ADA fountain height requirement of 34 1/4" to the bubbler spout.
- Install purifier cabinet in rough opening below the mounting plate using 3/16" holes in the side flange of the cabinet. Purifier cabinet should be located approx. 1/4" below and centered with the mounting plate above.
- Install cover plate over mounting plate, and slide each fountain and vandal proof bottle filler arm (if ordered) over the horizontal tongues protruding from the mounting plate and fasten arms with set screws pushing slightly against the cover plate.
- Connect drain line to slip coupling at each fountain and connect supply line to filter housing.

Purifier Cabinet Mounting Detail

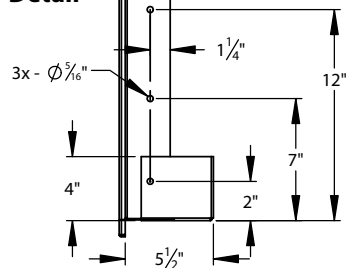

Typical Drain Plumbing Detail (In-Wall Drain Plumbing Provided By Others, Install Per Local Code)

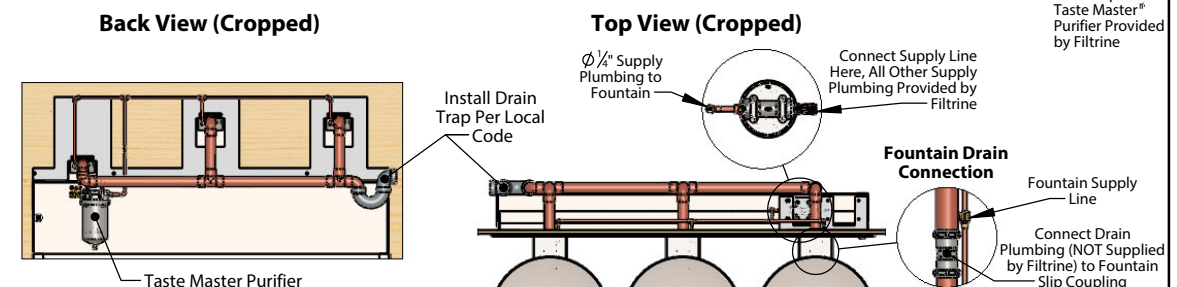

Unions, Elbows, and Adapters for Taste Master® Purifier Provided by Filtrine