

107-16-HHL-VP

Non-Recessed Vandal Proof
Triple Bowl Drinking Fountain with Vandal Proof Bottle Filler



Fountain bowls, cover plate and vandal proof bottle filler* shown in standard stainless steel satin finish with "Soft Touch" button valves* and bubblers* in mirror finish

*"Hands Free" option available

Dimensions in drawing subject to options selected.

Features

- [3] 16" diameter, 16 ga. fountain bowls
- No plastic parts
- 100% made in the USA
- Manufactured with lead-free materials
- Integral drain in bowl for ease of cleaning
- 1/4" steel support arm and wall bracket capable of supporting 500 lbs.
- Cover plate and optional access panel to match bowl finish or choose from unlimited powder coat colors
- Options include vandal proof bubblers, bottle fillers, bottle counters, finishes, bubbler valves, and more...

Recommended Add-ons

Chiller

Equip your fountain with a Filtrine point-of-use or remote chiller to cool your drinking water. We can help you select the most economical chiller model to fit your demand.

Purifier

Ensure that your drinking water is of the highest quality by adding a Filtrine Taste Master™ purifier cabinet underneath the fountain or a remote purification system serving all fountains in the building.

Top View

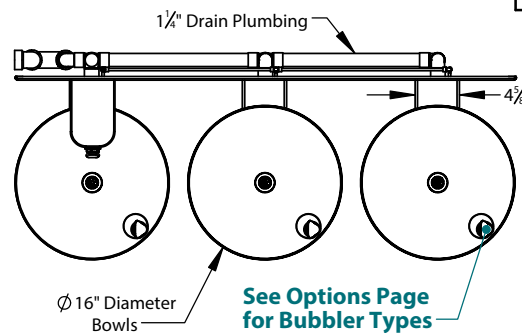

Select Low Fountain Location

Left [S] Middle Right

Side View

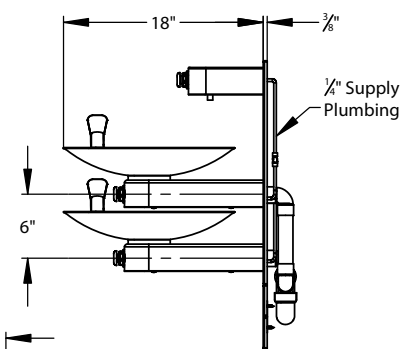

Front View

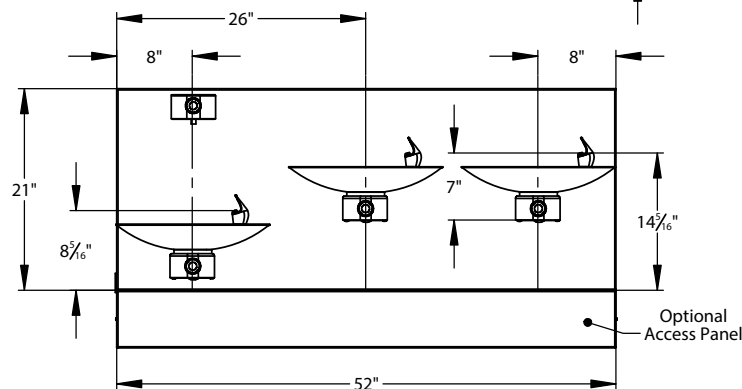

For options, finishes and more see page 2



Vandal Proof Non-Recessed Fountain Options

[S] - Standard
[ADA] - ADA compliant

Standard Vandal Proof Bottle Filler

Features:

- Mounted 10½" above lowest fountain bowl
- Comes standard with bottom security panel assembled with tamper proof screws and "Soft Touch" button valve
- Supply plumbing and mounting tongue for filler provided by Filtrine

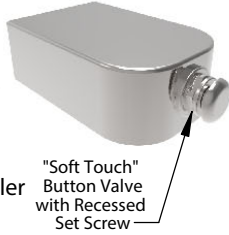

Bubbler Control Options (Check One)



Bottle Filler Options

"Hands Free" Sensor Activated

- 4x -AA lithium batteries (included)
- Runs approximately 400,000 cycles
- Features automatic shutoff (30 sec)
- Includes 6" access panel below fountain for sensor controls (see below)

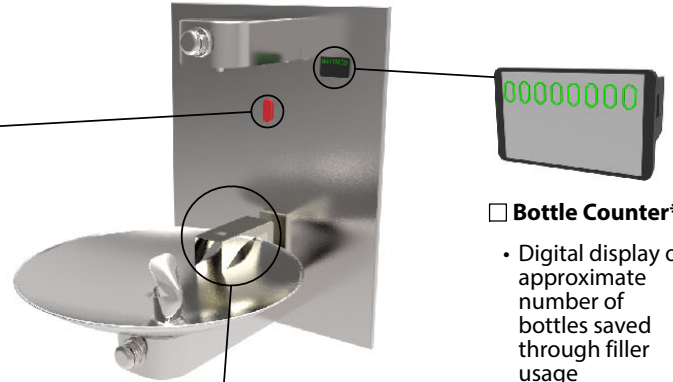

Bottle Rest**

- Located above lowest fountain for reduced splash and one handed operation
- **Recommended with sensor activation

Standard Security Panel and Vandal Proof Bubbler

"Soft Touch" Button and Projector Bubbler with Recessed Set Screws

16 ga. Plate Secured with Tamper-Resistant Screws for Added Security

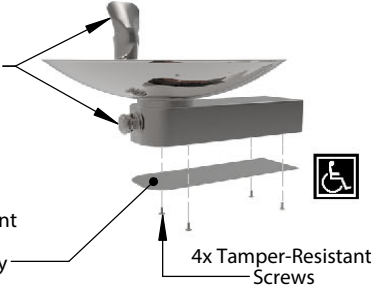

Standard 21" High Cover Plate

- 16 gauge metal construction
- Material and finish for cover plate can be selected below

Cover Plate Friction Fit on Mounting Plate



Access Panel Options

- 6" Standard Height
- Other Height _____ in

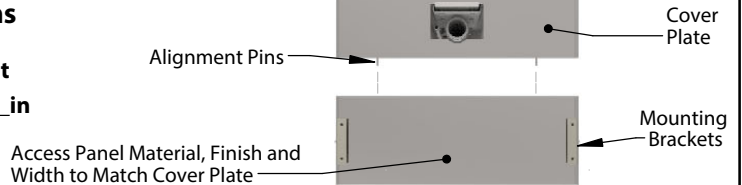

Fountain Finish (Check One)

- Satin Stainless [S] Mirrored Stainless Powder Coat _____ Satin Bronze Mirrored Bronze Statuary Bronze Oil-Rubbed Bronze

Cover Plate Finish (Check One)

- Satin Stainless [S] Mirrored Stainless Powder Coat _____ Satin Bronze Mirrored Bronze Statuary Bronze Oil-Rubbed Bronze

Stainless



Satin Stainless Steel [S]



Mirrored Stainless Steel

Bronze

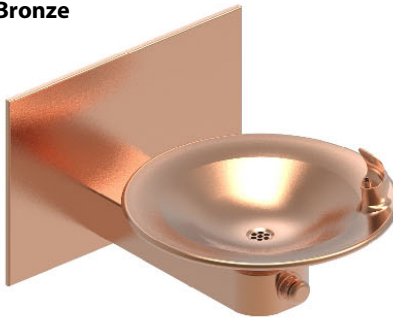

Satin Bronze

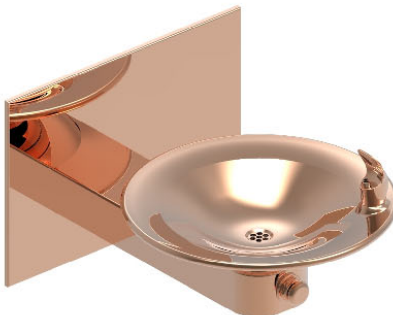

Mirrored Bronze



Oil Rubbed Bronze



Statuary Bronze



Mounting Plate Details (Front)

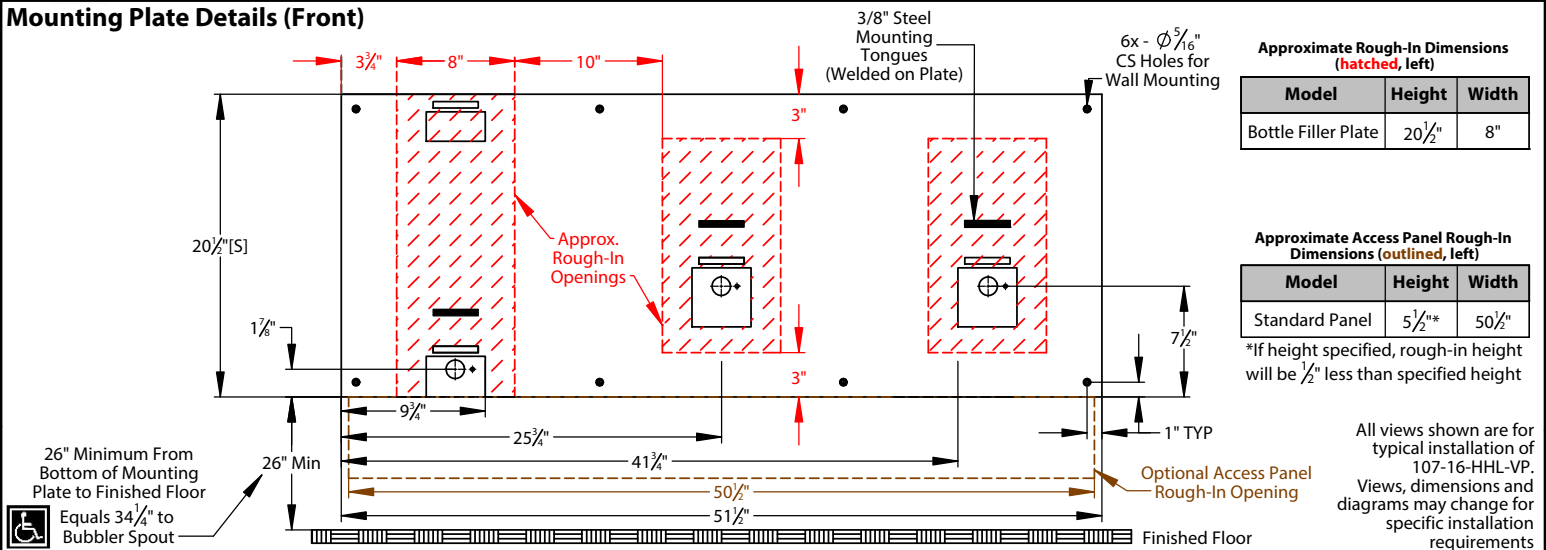

Approximate Rough-In Dimensions (hatched, left)

Model	Height	Width
Bottle Filler Plate	20 1/2"	8"

Approximate Access Panel Rough-In Dimensions (outlined, left)

Model	Height	Width
Standard Panel	5 1/2"*	50 1/2"

*If height specified, rough-in height will be 1/2" less than specified height

All views shown are for typical installation of 107-16-HHL-VP. Views, dimensions and diagrams may change for specific installation requirements

Exploded On-Wall Installation View 107-16-HHL-VP with Access Panel

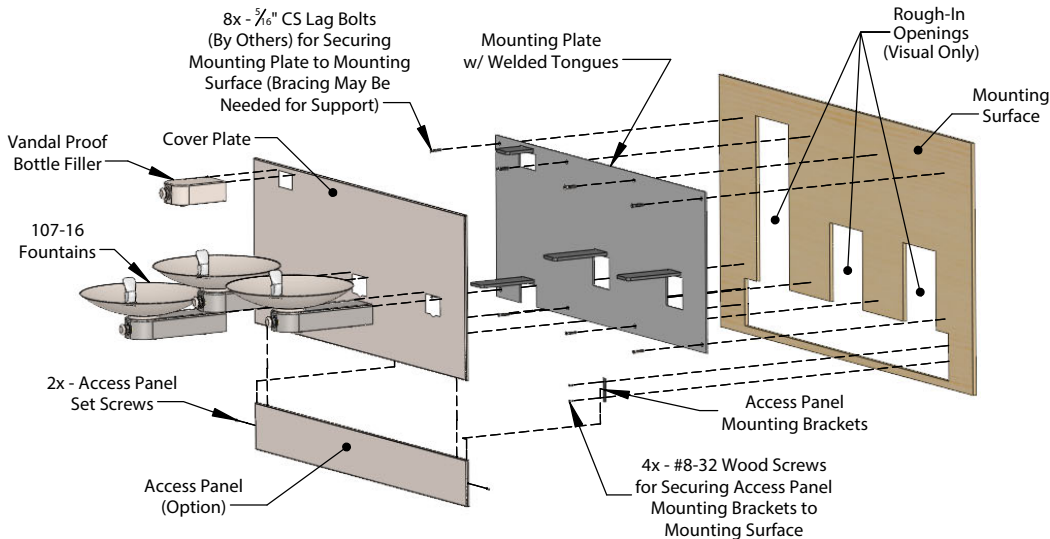

Two Methods for Mounting Model 107-16-HHL-VP to Wall

On-wall Mounting Detail With Cover Plate

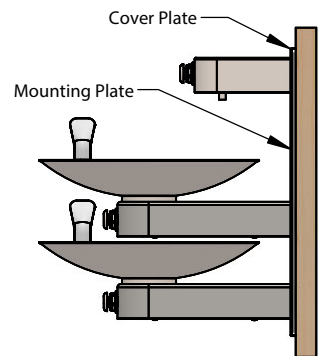

Behind-wall Mounting Detail Without Cover Plate

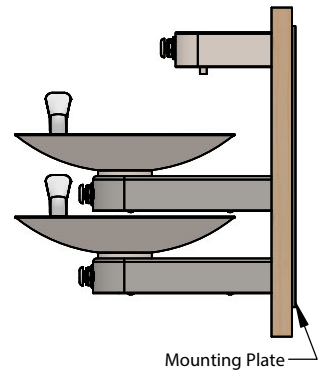

Typical Assembly Instructions (Always Install Per Local Code)

1. Cut rough opening as shown above and install blocking or fixture carrier as required to support the assembly.
2. If optional access panel was ordered cut a separate rough opening (table, top right) extending below the fountain mounting plate.
3. Run drain piping to center of openings on mounting plate, and install drain traps in wall per local code.
4. Run supply water lines with service valve, if necessary.
5. Attach piping assembly provided by Filtrine to the back side of the mounting plate with two screws and rubber gasket for standard bottle filler and flare connection for vandal proof bottle filler.
6. Fasten mounting plate over rough opening with 5/16" countersunk lag bolts with bottom of plate 26" above the floor to meet ADA fountain height requirement of 34 1/4" to the bubbler spout.
7. Install cover plate over the mounting plate for on-wall installations.
8. Slide each fountain and vandal proof bottle filler arm over the horizontal tongues protruding from the mounting plate and fasten arms with set screws pushing slightly against the cover plate or finished wall.
9. Connect drain plumbing to slip coupling and connect water supply connections.
10. If your model includes the access panel, measure, mark and install the included "L" brackets with #8-32 screws and align panel to cover plate with alignment pins.

Access Panel Mounting Brackets Installation Details

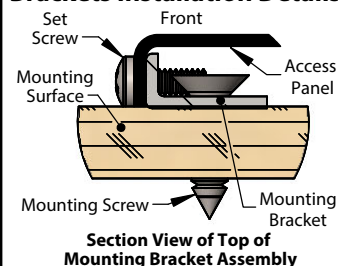

Typical Drain Plumbing Detail (In-Wall Plumbing Provided By Others, Install Per Local Code)

