



Fountain bowl, cover plate and purifier cabinet shown in standard stainless steel satin finish with "Soft Touch" button valve* and bubbler in mirror finish with a Taste Master® purifier (in cabinet)

*"Hands free" option available

Dimensions in drawing subject to options selected.

Features

- 14" diameter, 16 ga. fountain bowl
- No plastic parts
- 100% made in the USA
- Manufactured with lead-free materials
- Integral drain in bowl for ease of cleaning
- 1/4" steel support arm and wall bracket capable of supporting 500 lbs.
- Matching cover plate and cabinet finishes including unlimited powder coat colors
- Options include vandal proof bubblers, bottle fillers, bottle counters, finishes, bubbler valves, and more...

107-14-TM Models Include: Purifier: Taste Master® TMS1-0.5

- **Construction:** Stainless steel housing
- **Element:** Carbon block removes particulates, cysts, chlorine, organic odors and tastes. Exclusive seal design negates bypassing and leaking.

Recommended Add-ons

Chiller

Equip your fountain with a Filtrine point-of-use or remote chiller to cool your drinking water. We can help you select the most economical chiller model to fit your demand.

Top View

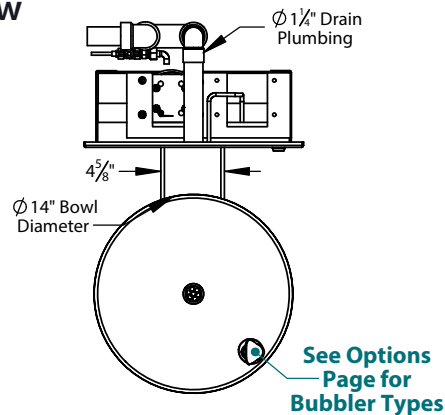

Front View

See Options Page for Bottle Filler Types

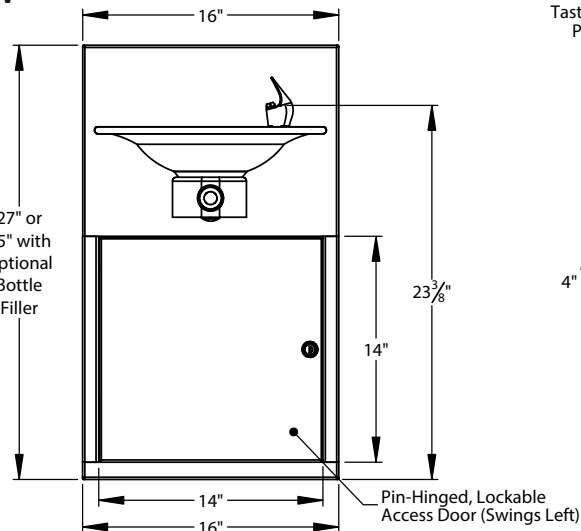

Side View

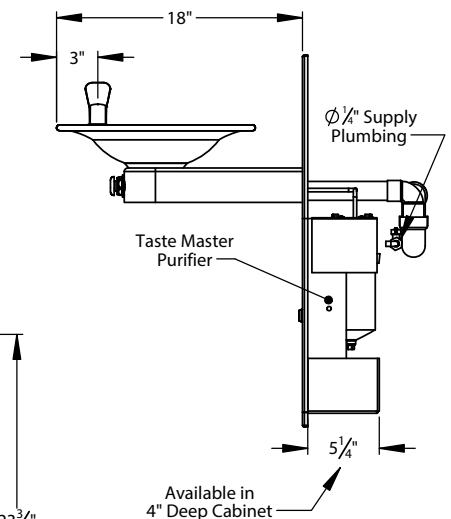

For options, finishes and more see page 2



Filtrine Drinking Water Non-Recessed Fountain Options

[S] - Standard
[♿] - ADA compliant

Optional Vandal Proof Bottle Filler (Choose only one optional filler)

"Soft Touch" Valve Sensor Activation*

- Bottle Rest - Located above lowest bowl for reduced splash and one handed operation
- Bottle Counter - Digital display of approx. number of bottles saved through fountain usage
Note: Only available with sensor activation



- Mounted 10" above lowest fountain bowl.
- Comes standard with bottom security panel assembled with tamper proof screws.
- Requires larger cover plate and mounting plate.
- Supply plumbing and mounting tongue for filler provided by Filtrine.

Optional Integral "Push Back" Lever Bottle Filler (Choose only one optional filler)

- Mounted 10" above lowest fountain bowl.
- Requires larger cover and mounting plates.
- Easy-to-use stainless steel "push back" lever.
- Supply plumbing and mounting fitting for filler provided by Filtrine.



Optional Security Panel

16 ga. Plate Secured with Tamper-Resistant Screws for Added Security

4x-Tamper-Resistant Screws



Bubbler Controls (Check One)

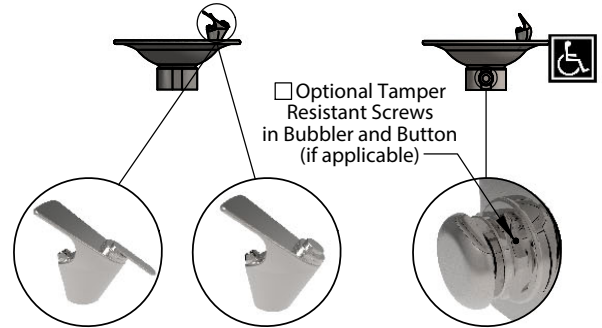

Optional Tamper Resistant Screws in Bubbler and Button (if applicable)

"Easy Touch" Lever Valve

"Push Button" Valve

"Soft Touch" Button Valve [S]

Optional Fountain Sensor Activated Bubbler



"Hands Free" Sensor Activator

- Uses 4x -AA lithium batteries (included), runs approximately 400,000 activation cycles*.

- Features automatic shutoff (30 sec).

- Helps prevent germ transmission, vandalism and water waste.

*120/60/1 voltage available

Fountain Finish (Check One)

Satin Stainless [S] Mirrored Stainless Powder Coat _____ Satin Bronze Mirrored Bronze Statuary Bronze Oil-Rubbed Bronze

Cover Plate Finish (Check One)

Satin Stainless [S] Mirrored Stainless Powder Coat _____ Satin Bronze Mirrored Bronze Statuary Bronze Oil-Rubbed Bronze

Stainless



Satin Stainless Steel [S]



Mirrored Stainless Steel

Bronze



Satin Bronze

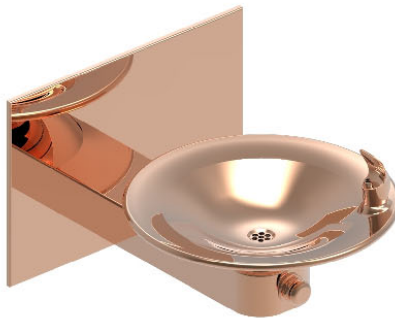

Mirrored Bronze



Oil Rubbed Bronze



Statuary Bronze



Mounting Plate Details (Front)

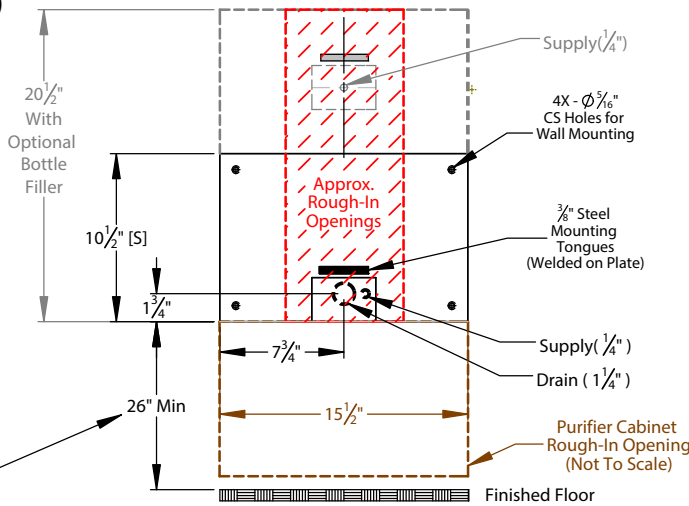

Approximate Rough-In Dimensions (hatched, left)

Model	Height	Width
Standard Plate	10 1/2"	8"
Bottle Filler Plate	20 1/2"	8"

Approximate Purifier Cabinet Rough-In Dimensions (outlined, left)

Model	Height	Width
Purifier Cabinet*	15"	15 1/2"

*Wall opening must be 6" deep to allow room purifier and plumbing

All views shown are for typical installation of 107-14-TM. Views, dimensions and diagrams may change for specific installation requirements.

26" Minimum From Bottom of Mounting Plate to Finished Floor

Equals 34 1/4" to Bubbler Spout

Exploded On-Wall Installation View for 107-14-TM

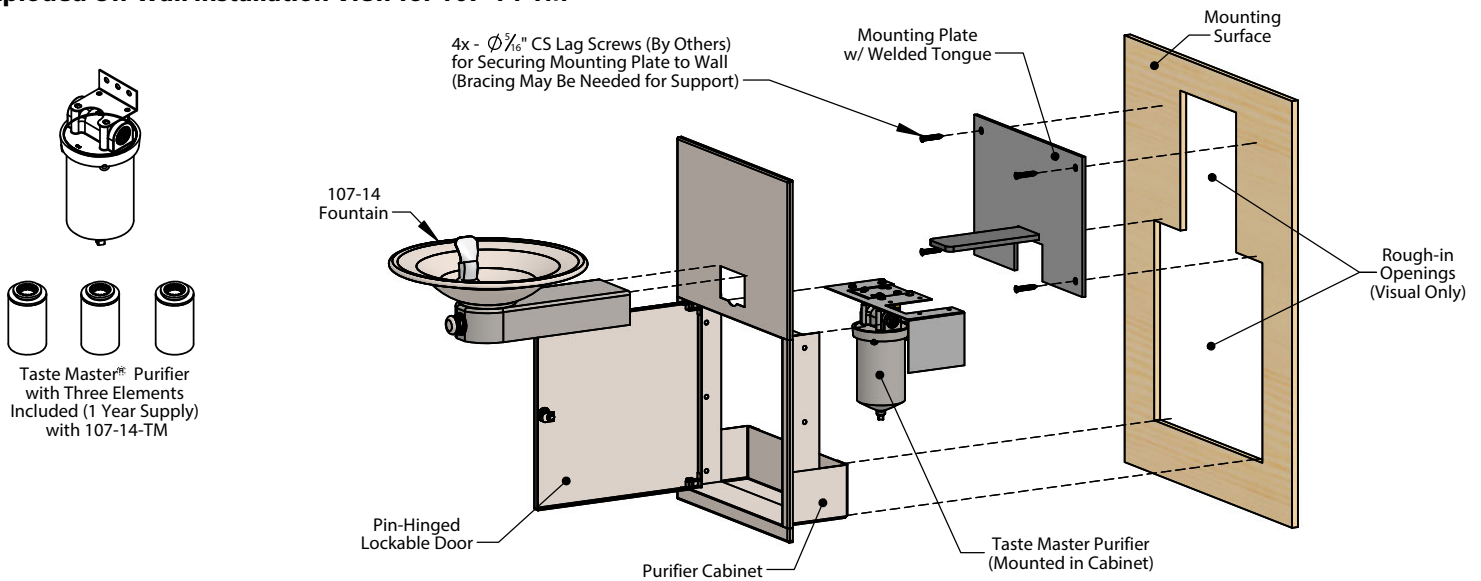

Typical Assembly Instructions (Always Install Per Local Code)

- Cut rough openings per install requirements (rough opening example shown above) and install blocking or fixture carriers as required to support the drinking fountain mounting plate and purifier cabinet in a minimum 6" deep wall.
- Run drain piping to center of openings on mounting plate (dimensioned above), and install drain trap(s) in wall per local code.
- Run supply water line to mounted Taste Master filter housing.
- If optional bottle filler is included with order, attach piping assembly provided by Filtrine to the back side of the mounting plate with two screws and rubber gasket for standard bottle filler and flare connection for vandal proof bottle filler.
- Fasten mounting plat to mounting surface over rough opening with 5/16" countersunk lag bolts with bottom of plate 26" above the floor to meet ADA fountain height requirement of 34 1/4" to the bubbler spout.
- Install cover plate including the purifier cabinet over the mounting plate. Using lag screws fasten the cabinet to the blocking or the mounting surface through the side flange of the cabinet.
- Slide each fountain and vandal proof bottle filler arm (if ordered) over the horizontal tongues and threaded connections protruding from the mounting plate. Fasten arms with set screws pushing slightly against the cover plate.
- Connect drain line to slip coupling at each fountain and connect provided supply line from purifier housing to fountain. Install security panel under arm using tamper proof screws (if applicable).
- Connect building water line to 1/4" FPT stop valve at purifier inlet.
- Install filter cartridge in housing per instructions on filter. Open stop valve to fill filter housing. Activate a bubbler and hold until all air in the line is purged.

Chiller Cabinet Mounting Detail

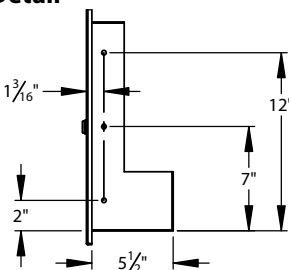

Typical Drain Plumbing Detail (In-Wall Drain Plumbing Provided By Others, Install Per Local Code)

Back View (Cropped)

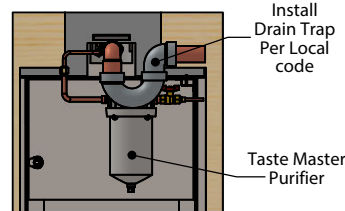

Top View (Cropped)

