



# 107-14-TM

## Non-Recessed Vandal Proof Drinking Fountain with In-Wall Taste Master® Purifier



Bottle filler\*, fountain support arm, cover plate, purifier cabinet, "Soft Touch" button valve\*, and bubbler\* shown in standard stainless steel satin finish

### PRODUCT COMPLIANCE\*

ADA Compliance  
Buy America Act  
CA Proposition 65  
NSF/ANSI 42, 53 and 372 (Lead Free)  
UL STD 399  
CSA STD C22.2 #120

\*More available on request

Options and finishes may differ from image shown.

\*"Hands Free" option available

Dimensions in drawing subject to options selected.

### Features

- 14" diameter, 16 ga. fountain bowl
- No plastic parts
- 100% made in the USA
- Manufactured with lead-free materials
- Integral drain in bowl for ease of cleaning
- 1/4" steel support arm and wall bracket capable of supporting 500 lbs.
- Long-lasting, durable stainless steel water dispenser, promotes refilling of water bottles
- 16 ga. plate secured with tamper-resistant screws for added security
- Pin-hinged, lockable door
- Options include sensor activation, bottle fillers, bottle counters, finishes, bubbler valves, and more...

### Top View

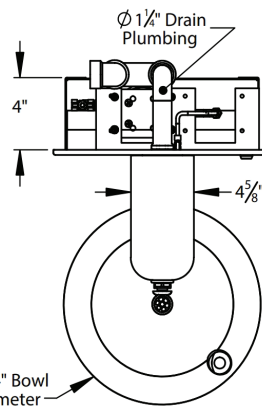

### Front View

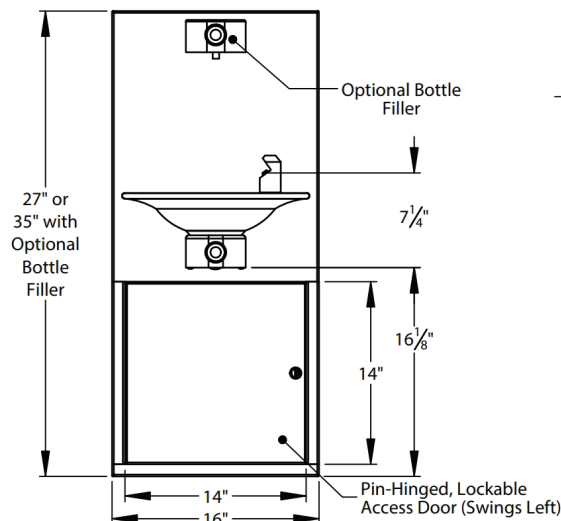

### Side View

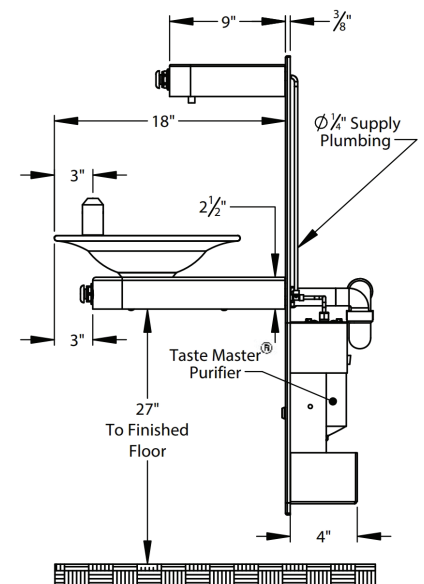

### 107-14-TM Models Include:

#### Purifier: Taste Master® TMS1-0.5

- **Construction:** Stainless steel housing
- **Element:** Carbon block removes particulates, cysts, chlorine, organic odors and tastes. Exclusive seal design negates bypassing and leaking.

### Recommended Add-ons

#### Chiller

Equip your fountain with a Filtrine point-of-use or remote chiller to cool your drinking water. We can help you select the most economic chiller model to fit your demand.

For options, finishes and more see page 2

Filtrine Mfg. Co. • 15 Kit St. Keene, NH 03431 USA  
800-930-3367 • 603-352-5500 • FAX 603-352-0330  
www.filtrine.com • drinking\_water@filtrine.com



FILTRINE IS ISO 9001:2015 CERTIFIED BY NSAI  
PRODUCT LINE APPROVED MARK AVAILABLE



107-14-TM [EB]

REVISED

12.11.25



# Filtrine Drinking Water Non-Recessed Fountain Options

[S] - Standard

- ADA Compliant

## Standard Security Panel and Vandal Proof Bubbler [S]



"Soft Touch" Button and Projector Bubbler with Recessed Set Screws



16 ga. Plate Secured with Tamper-Resistant Screws for Added Security

## Standard Bubbler Controls

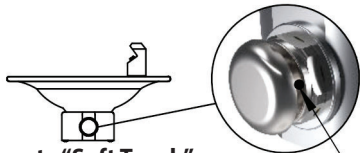

Remote "Soft Touch" Button Valve [S]

Tamper-Resistant Screws in Bubbler and "Soft Touch" Button(if applicable)

## "Hands Free" Options



### Bottle Counter\*

• Digital display of approximate number of bottles saved through filler usage

\*Only available with "Hands Free" units

### Bottle Rest

• Located above fountain for reduced splash and one handed operation



### "Hands Free" Sensor Activated Bottle Filler

- Features automatic shutoff (20 sec)
- Helps prevent vandalism and water waste

### Power Supply Options: (Choose only one)

Connect 12v Transformer to A/C Power Supply [S] or

Use 12v Wall Plug

120/60/1 Voltage Required

### "Hands Free" Sensor Activated Bubbler

## Optional Bottle Fillers (Choose only one optional filler)

- Mounted 10½" above fountain bowl
- Requires larger cover plate
- Comes standard with tamper proof screws
- Supply plumbing for filler provided by Filtrine

### "Soft Touch" Button Vandal Proof Filler\*



\*Hands Free options available

### "Soft Touch" Button F-520 Bottle Filler\*



\*Hands Free options available

Other options are available, please contact the factory for more choices.

Vandal Proof Option:  Yes [S]  No

## Bubbler Options:



F-507

All finish options available



F-501



F-501-L



F-502

Available in:  
Stainless Steel,  
Oil-Rubbed Bronze,  
or Any Powder Coat  
Options

## Fountain Finish (Check One)

Satin Stainless [S]  Satin Bronze  Statuary Bronze  Oil-Rubbed Bronze  Oil-Rubbed Bronze Powder Coat  Powder Coat \_\_\_\_\_

## Optional Cover Plate Finish (Check One)

Satin Stainless [S]  Satin Bronze  Statuary Bronze  Oil-Rubbed Bronze  Oil-Rubbed Bronze Powder Coat  Powder Coat \_\_\_\_\_



Satin Stainless Steel [S]

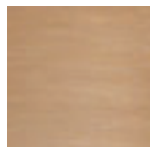

Satin Bronze

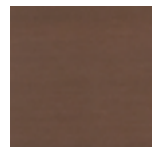

Statuary Bronze

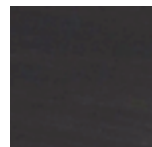

Oil Rubbed Bronze

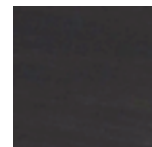

Oil Rubbed Bronze Powder Coat  
(Applied to Stainless Steel)



Powder Coat

Filtrine Mfg. Co. • 15 Kit St. Keene, NH 03431 USA  
800-930-3367 • 603-352-5500 • FAX 603-352-0330  
[www.filtrine.com](http://www.filtrine.com) • [drinking\\_water@filtrine.com](mailto:drinking_water@filtrine.com)



FILTRINE IS ISO 9001:2015 CERTIFIED BY NSAI  
PRODUCT LINE APPROVED MARK AVAILABLE



107-14-TM [EB]

REVISED

12.11.25

## Mounting Plate Details (Front)

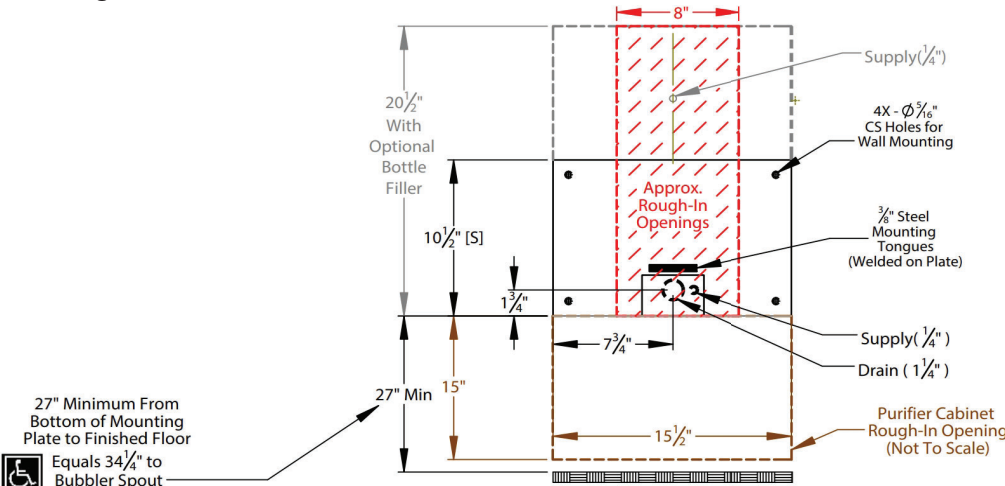

## Mounting Plate Rough-In Dimensions (hatched, left)

MODEL	HEIGHT	WIDTH
107 Fountain	10"	8"
107 Fountain with Optional Filler	19"	8"

## Access Panel Rough-In Dimensions (hatched, left)

MODEL	HEIGHT	WIDTH	DEPTH
Chiller Cabinet	15"	15 1/2"	4"

All views shown are for typical installation of 107-14-TM.

Views, dimensions and diagrams may change for specific installation requirements

## Exploded On-Wall Installation View 107-14-TM

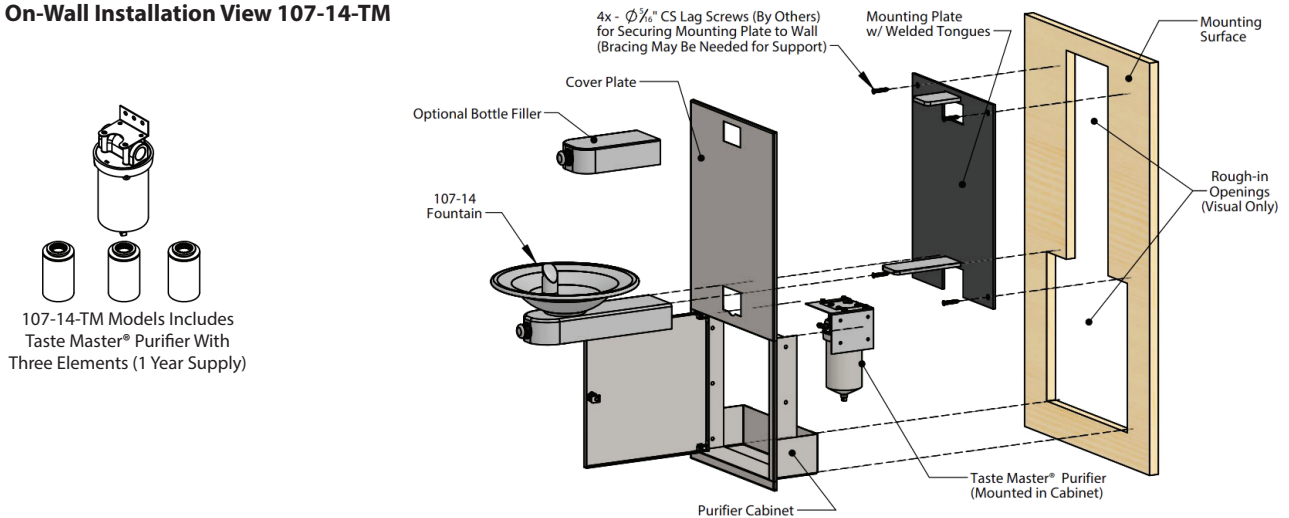

## Typical Assembly Instructions (Always Install Per Local Code)

- Cut rough opening per install requirements (rough opening example shown above) and install blocking or fixture carriers as required to support the drinking fountain mounting plate and purifier cabinet in a minimum 4" deep wall.
- Run drain piping to center of openings on mounting plate (dimensioned above), and install drain trap(s) in wall per local code.
- Run supply water line to mounted Taste Master® filter housing.
- If optional bottle filler is included with order, attach piping assembly provided by Filtrine to the back side of the mounting plate with two screws and rubber gasket for standard bottle filler and flare connection for vandal proof bottle filler.
- Fasten mounting plate to mounting surface over rough opening with  $\frac{5}{16}$ " countersunk lag bolts with bottom of plate 27" above the floor to meet ADA fountain height requirement of 34 1/4" to the bubbler spout.
- Install cover plate including the purifier cabinet over the mounting plate. Using lag screws, fasten the cabinet to the blocking or the mounting surface through the side flange of the cabinet.
- Slide each fountain and vandal proof bottle filler arm (if ordered) over the horizontal tongues and threaded connections protruding from the mounting plate. Fasten arms with set screws pushing slightly against the cover plate.
- Connect drain line to slip coupling at each fountain and connect provided supply line from purifier housing to fountain. Install security panel under arm using tamper proof screws (if applicable).
- Connect building water line to 1/4" FPT stop valve at purifier inlet.
- Install filter cartridge in housing per instructions on filter. Open stop valve to fill filter housing. Activate a bubbler and hold until all air in the line is purged.

## Purifier Cabinet Installation Details

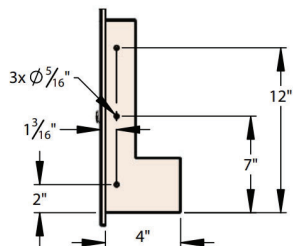

## Typical Drain Plumbing Detail (In-Wall Plumbing Provided by Others, Install Per Local Code)

