

# FILTRINE

Model 90-PA  
Non-Recessed Fountain

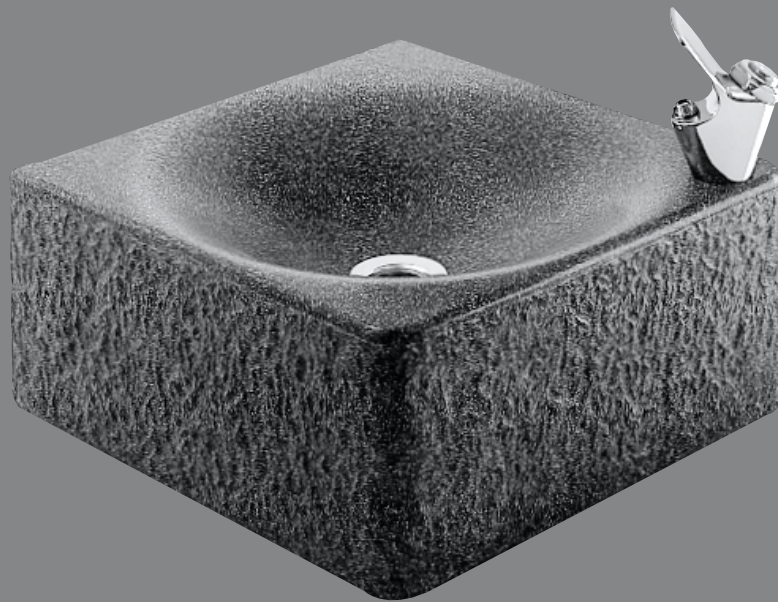

Model 90-PA Non-Recessed Fountain  
shown in Polymer Aggregate with rough-cut  
sides and equipped with mirror finish  
push-button bubbler and drain.

FORM 1251

# SPECIFICATIONS Model 90-PA

Supply and install where shown on plans, wall mounted rectangular faux stone drinking fountain. Receptor to be an integral 10" bowl. Fountain to be secured to wall by a concealed mounting plate. Overall fountain height not to exceed 5 1/2".

## MATERIAL:

- Polymer Aggregate type[ ]
- (See Bulletin 1610 for selection)

FIXTURE & DRAIN:  Chrome Plated  Bronze

## FINISH:

FIXTURE & DRAIN:  Satin  Mirror

## FIXTURES:

- Bubbler with integral push-button valve (shown)
- Bubbler with separate lever handle valve
- Bubbler with dual lever handle valves
- Bubbler with separate "Soft Touch" valve
- Bubbler with wrist bar valve
- Bubbler with rocker arm valve
- Bubbler with "No Hands" photo cell in cover plate.
- Gooseneck glass filler with "Soft Touch" valve (in place of bubbler).

## MOUNTING PLATE:

- IN-WALL: 1/4" Steel plate to be 10 3/4" high for vertical stability and 15 3/4" wide.
- ON-WALL: As above with 16"W x 1/2"D x 11"H cover plate to match fountain.



**MODEL 90-PA CAN BE MODIFIED TO MEET A.D.A. REQUIREMENTS AS STATED BELOW**

**4.15.2 SPOUT HEIGHT:** Spouts shall be no higher than 36" measured from the floor or ground surfaces to the spout outlet.

**4.15.3 SPOUT LOCATION:** The spouts of drinking fountains and water coolers shall be at the front of the unit and shall direct the water flow in a trajectory that is parallel or nearly parallel to the front of the unit. On an accessible drinking fountain with a round or oval bowl, the spout must be positioned so the flow of water is within 3" of the front edge of the fountain.

**4.15.4. CONTROLS:** Unit controls shall be front mounted or side mounted near the front edge.

**4.15.5.1 CLEARANCES:** Wall and post-mounted cantilevered units shall have a clear knee space between the bottom of the apron and the floor or ground at least 27" high, 30" wide and 17" to 19" deep. Such units shall also have a minimum clear floor space 30" by 48" to allow a person in a wheelchair to approach the unit facing forward.

Federal Register, July 28, 1991  
Rules and Regulations

## INSTALLATION DRAWINGS

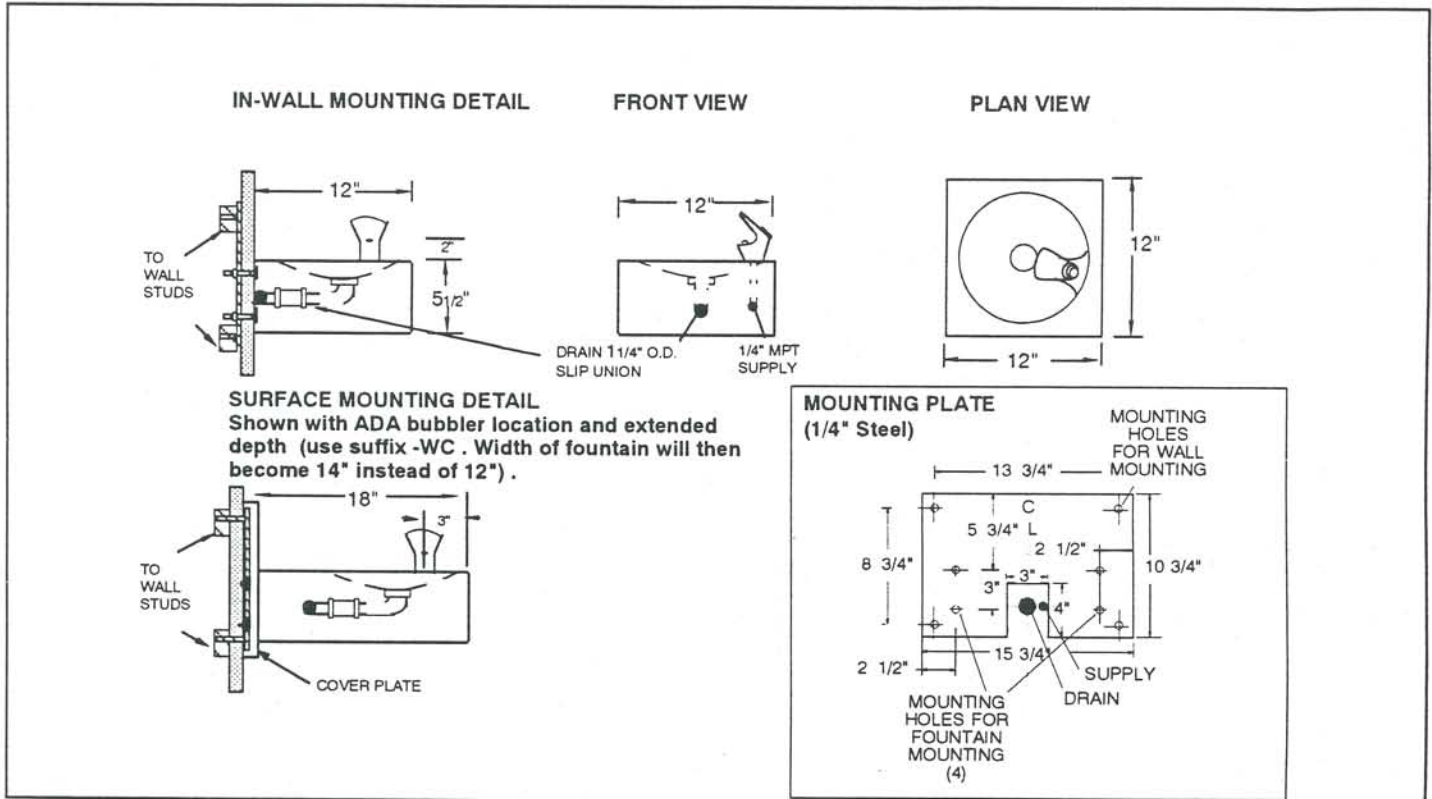

**FILTRINE MANUFACTURING COMPANY** Keene, NH 03431  
(603) 352-5500 • (800) 930-3367 • Fax (603) 352-0330  
Website: www.filtrine.com