

FILTRINE

Model 90 Non-Recessed Fountain



Model 90 Non-Recessed Fountain shown in satin finish stainless steel with chrome finish bubbler.

Shown with mounting plate concealed behind wall.

ALSO AVAILABLE:
Model 90-CP Non-Recessed Fountain shown in satin finish stainless steel with chrome finish bubbler.

Shown with surface mounting plate and matching cover plate.



SPECIFICATIONS Model 90

Supply and install where shown on plans, wall mounted rectangular drinking fountain. Receptor to be an integral 10" bowl. Fountain to be secured to wall by a concealed mounting plate. Overall fountain height not to exceed 5 1/2".



MODEL 90 CAN BE MODIFIED TO MEET A.D.A. REQUIREMENTS AS STATED BELOW

MATERIAL:

- Stainless Steel (16 gauge)
- Bronze (16 gauge)
- FIXTURE & DRAIN: Chrome Plated Bronze

FINISH:

- FOUNTAIN: #4 Satin #8 Mirror
- Statuary Bronze
- FIXTURE & DRAIN: Satin Mirror

FIXTURES:

- Bubbler with integral push-button valve (shown)
- Bubbler with separate lever handle valve
- Bubbler with dual lever handle valves
- Bubbler with separate "Soft Touch" valve
- Bubbler with wrist bar valve
- Bubbler with rocker arm valve
- Bubbler with "No Hands" photo cell in cover plate.
- Gooseneck glass filler with "Soft Touch" valve (in place of bubbler).

MOUNTING PLATE:

- IN-WALL: 1/4" Steel plate to be 10 3/4" high for vertical stability and 15 3/4" wide.
- ON-WALL: As above with 16"W x 1/2"D x 11"H cover plate to match fountain.

4.15.2 SPOUT HEIGHT: Spouts shall be no higher than 36" measured from the floor or ground surfaces to the spout outlet.

4.15.3 SPOUT LOCATION: The spouts of drinking fountains and water coolers shall be at the front of the unit and shall direct the water flow in a trajectory that is parallel or nearly parallel to the front of the unit. On an accessible drinking fountain with a round or oval bowl, the spout must be positioned so the flow of water is within 3" of the front edge of the fountain.

4.15.4. CONTROLS: Unit controls shall be front mounted or side mounted near the front edge.

4.15.5.1 CLEARANCES: Wall and post-mounted cantilevered units shall have a clear knee space between the bottom of the apron and the floor or ground at least 27" high, 30" wide and 17" to 19" deep. Such units shall also have a minimum clear floor space 30" by 48" to allow a person in a wheelchair to approach the unit facing forward.

Federal Register, July 28, 1991
Rules and Regulations

INSTALLATION DRAWINGS

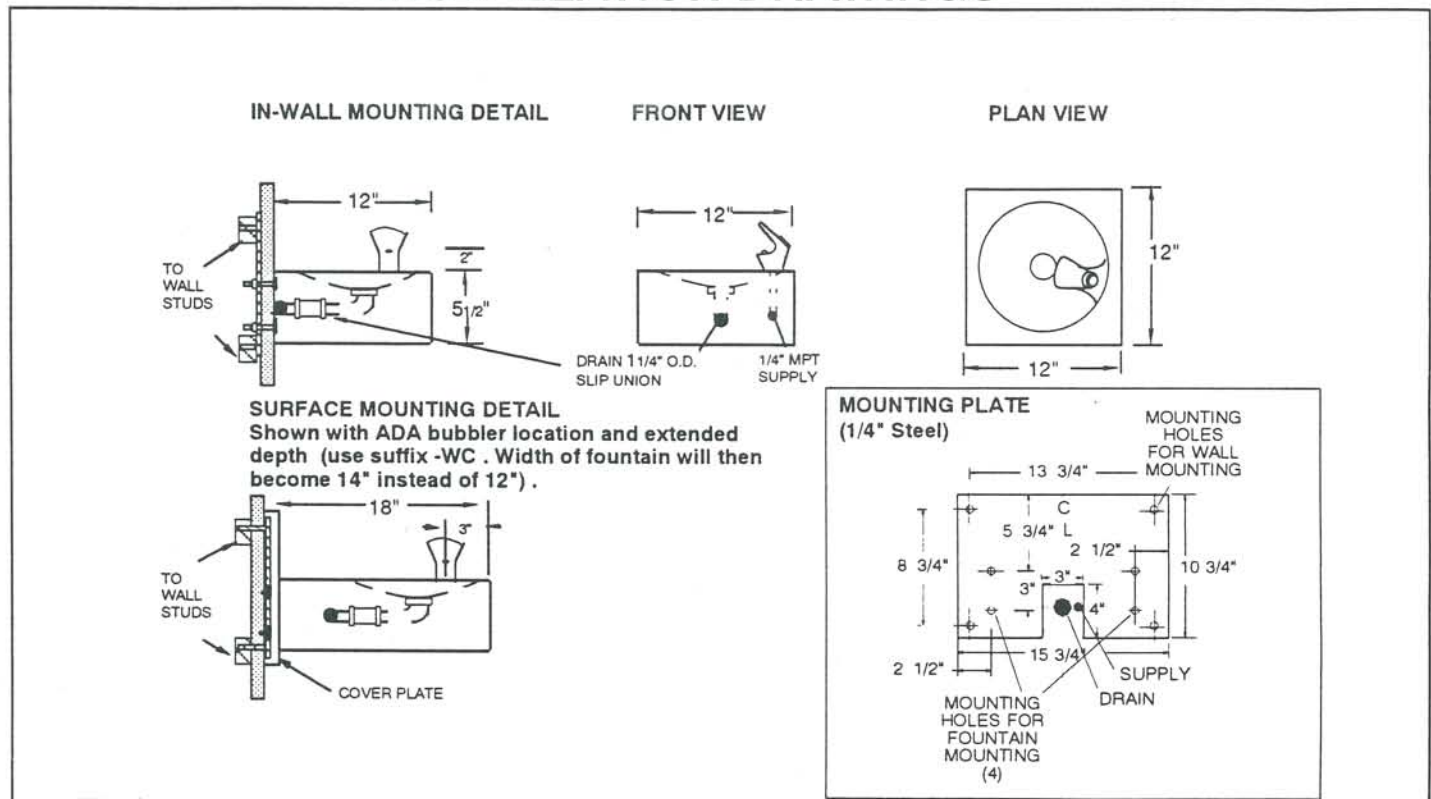

FILTRINE MANUFACTURING COMPANY Keene, NH 03431
(603) 352-5500 • (800) 930-3367 • Fax (603) 352-0330
Website: www.filtrine.com