

FILTRINE

Model 125-CP Pedestal Fountain



Model 125-CP Pedestal Fountain
(background) shown in #4 satin finish bronze with
mirror finish bronze push button bubbler and drain.

Model 125-CP PEDESTAL FOUNTAIN SPECIFICATIONS

Supply and install where shown on plans, floor mounted cylindrical drinking fountain. Receptor to be 11" diameter with concealed plumbing and tamper proof matching access panel in pedestal.

MATERIAL:

- FOUNTAIN: 16 gauge Stainless Steel
- Bronze

FINISH:

- FOUNTAIN: #4 Satin #8 Mirror
- Statuary Bronze
- FIXTURE & DRAIN: Satin Mirror
- Statuary Bronze

FIXTURES:

- Bubbler with integral push-button valve (shown)
- Bubbler with "Soft Touch" Button
- Bubbler with Separate Lever Handle Valve

MOUNTING PLATE: Fountain to be secured to floor by 1/4" steel base plate, 11" diameter overall, secured with (4) 4 1/2" anchor bolts and anchors.



MODEL 125-CP CAN BE MODIFIED TO MEET A.D.A. REQUIREMENTS AS STATED BELOW

4.15.2 SPOUT HEIGHT: Spouts shall be no higher than 36" measured from the floor or ground surfaces to the spout outlet.

4.15.3 SPOUT LOCATION: The spouts of drinking fountains and water coolers shall be at the front of the unit and shall direct the water flow in a trajectory that is parallel or nearly parallel to the front of the unit. On an accessible drinking fountain with a round or oval bowl, the spout must be positioned so the flow of water is within 3" of the front edge of the fountain.

4.15.4. CONTROLS: Unit controls shall be front mounted or side mounted near the front edge.

4.15.5.2 CLEARANCES: Free-standing or built-in units not having a clear space under them shall have a clear floor space at least 30" by 48" that allows a person in a wheelchair to make a parallel approach to the unit.

Federal Register, July 28, 1991
Rules and Regulations

Model 125-CP SCHEMATIC

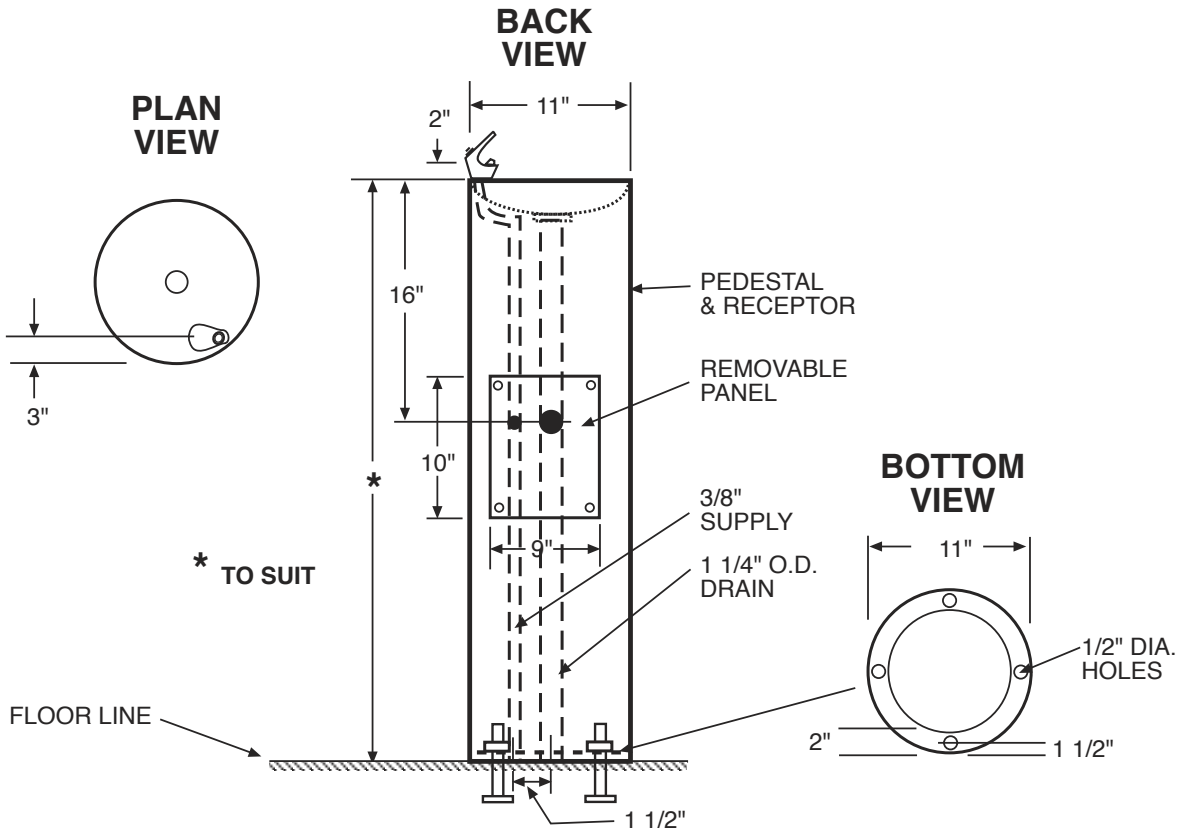

FILTRINE Mfg. Co. 15 Kit St. Keene, NH 03431 USA
866-491-2043 • 603-352-5500 • FAX: 603-352-0330
www.drinkingwater.filtrine.com • drinkingwater@filtrine.com

**Model 125-CP
PEDESTAL FOUNTAIN**

FORM 1150
08.01.08